

# 4 Motors and controllers

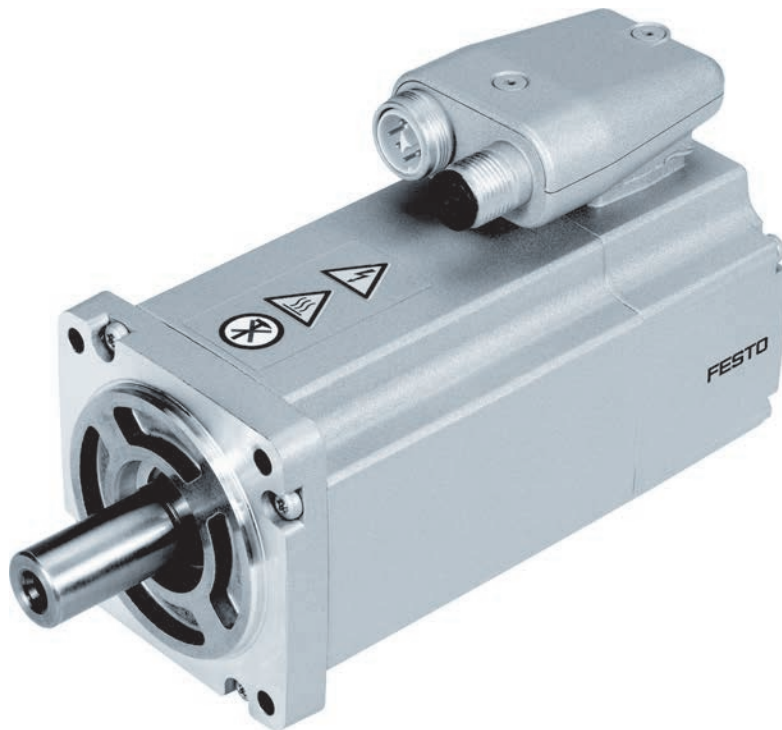

- + Servo motors
- + Stepper motors
- + Controllers and control systems
- + Gear unit for electromechanical drives
- + Accessories for position controllers and regulators

## Highlights



### EMME-AS

Servo motor



- + Brushless, permanently excited synchronous servo motor
- + Digital absolute displacement encoder, single turn or multi-turn

Page 518

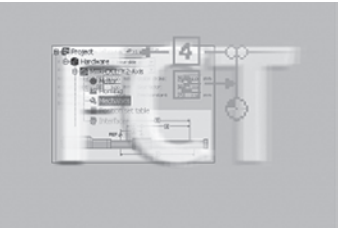

## Table of contents

Product overview .....	512
Servo motor EMME-AS .....	518
Servo motor EMMS-AS .....	530
Stepper motor EMMS-ST .....	549
Motor controller CMMP-AS .....	558
Motor controller CMMO-ST .....	565
Motor controller CMMS-ST .....	569
Gear unit EMGA-SST .....	574
Gear unit EMGA-SAS .....	577

## Software tool

<b>Festo Configuration Tool (FCT)</b>		<p>FCT is a configuration and parameterisation software program that supports all Festo devices, in particular motor controllers.</p> <p>It is extremely flexible, provides full support for the device properties and is simple and intuitive to operate. The user is guided step-by-step through the commissioning process while each individual step is checked.</p>	<p>The parameterisation software can be found on the website under Support &gt; Support Portal &gt; enter search term.</p>
<b>CODESYS</b>		<p>CODESYS for standardised programming of embedded devices according to IEC 61131-3. It makes your life easier with simple commissioning, quick programming and parameterisation.</p> <p>Advantages</p> <ul style="list-style-type: none"> <li>• Hardware-neutral software platform for quick and easy configuration, programming and commissioning of pneumatic and electric automation solutions</li> <li>• Extensive module libraries for single or multi-axis positioning motions</li> </ul>	<ul style="list-style-type: none"> <li>• The IEC 61131-3 standard means that CODESYS is flexible and open for all types of control tasks.</li> <li>• Modular: offline and online functions as well as components for hardware configuration and visualisation</li> <li>• User-friendly IEC function block extension</li> <li>• Re-use of existing application parts</li> </ul> <p>The parameterisation software can be found on the website under Support &gt; Support Portal &gt; enter search term.</p>

## Servo motors

Type	 <b>Servo motor EMME-AS</b>	 <b>Servo motor EMMS-AS</b>	 <b>Motor unit MTR-DCI</b>
<b>Nominal torque</b>	0.12 ... 6.4 Nm	0.14 ... 22.63 Nm	
<b>Nominal rotational speed</b>	3000 ... 9000 rpm	2000 ... 10300 rpm	3000 ... 3400 rpm
<b>Peak torque</b>	0.7 ... 30 Nm	0.5 ... 120 Nm	
<b>Max. rotational speed</b>	3910 ... 10000 rpm	2210 ... 23040 rpm	3000 ... 3400 rpm
<b>Description</b>	<ul style="list-style-type: none"> <li>• Brushless, permanently excited synchronous servo motor</li> <li>• Digital absolute displacement encoder, single turn or multi-turn</li> <li>• Reliable, dynamic, precise</li> <li>• Optimised connection technology</li> <li>• Over 40 stock types</li> <li>• Available with holding brake</li> </ul>	<ul style="list-style-type: none"> <li>• Permanently excited, electrodynamic, brushless servo motor</li> <li>• Digital absolute displacement encoder, single turn or multi-turn</li> <li>• 66 stock types</li> <li>• 490 built-to-order variants</li> <li>• Optionally with holding brake, IP65, resolver</li> <li>• Various winding variants</li> </ul>	<ul style="list-style-type: none"> <li>• DC motor with encoder</li> <li>• Gear unit, controller, power electronics integrated</li> <li>• RS232 parameterisation interface</li> <li>• I/O, PROFIBUS, CANopen, PROFIBUS DP, DeviceNet interface</li> <li>• Control panel with display, optional</li> <li>• Gear ratios: 7:1, 14:1, 22:1</li> </ul>
<b>→ Page/online</b>	<b>518</b>	<b>530</b>	<a href="#">mtr</a>



## Stepper motors

Type	 <b>Stepper motor EMMS-ST</b>
<b>Maximum speed</b>	430 ... 6000 1/min
<b>Motor holding torque</b>	0.09 ... 9.3 Nm
<b>Description</b>	<ul style="list-style-type: none"> <li>• Small increment and high driving torques by 2-phase hybrid technology</li> <li>• Optimised connection technology</li> <li>• 28 stock types</li> <li>• With incremental encoder for closed-loop operation</li> <li>• Available with holding brake</li> </ul>
<b>→ Page/online</b>	<b>549</b>



## Controllers for AC servo motors

Type	 <p><b>Motor controller C MMP-AS</b></p>
Nominal current	2 ... 20 A
Nominal operating voltage AC	230 ... 400 V
Nominal operating voltage phases	1-phase, 3-phase
Rated output of controller	500 ... 12000 VA
Fieldbus coupling	CANopen, DeviceNet, Ethernet, EtherNet/IP, PROFIBUS DP, PROFINET, Sercos
Description	<ul style="list-style-type: none"> <li>• Many interfaces and functions for decentral motion functions (flying saw, flying measurement, modulo function,...)</li> <li>• For cam disk controllers and highly dynamic movements</li> <li>• Standardised interfaces allow seamless integration in mechatronic multi-axis modular systems</li> <li>• Reliable and easy commissioning and parameterisation with the Festo Configuration Tool (FCT)</li> <li>• Optionally with 3 slots for switch or safety module, for extension module</li> <li>• Integrated process interfaces: Modbus/TCP, CAN bus and digital I/O module</li> <li>• Further extension modules: PROFIBUS, PROFINET, EtherCAT, ...</li> </ul>
→ Page/online	558



## Controllers for DC servo motors

Type	 <p><b>Motor controller SFC-LACI</b></p>	 <p><b>Motor controller SFC-DC</b></p>	 <p><b>End-position controller CMFL</b></p>
Nominal current, load supply	100	30	30
Nominal voltage, load supply DC	48 V	24 V	24 V or 48 V
Rated output of controller	480 VA	75 VA	
Fieldbus coupling	CANopen, DeviceNet, PROFIBUS DP	CANopen, DeviceNet, PROFIBUS DP	
Description	<ul style="list-style-type: none"> <li>• For controlling electric cylinder DNCE-LAS and guided drives DFME-LAS</li> <li>• Open-loop and closed-loop position controller</li> <li>• Easy actuation via I/O interface, PROFIBUS, CANopen</li> <li>• With or without control panel</li> <li>• Parameterisation via control panel or parameterisation software FCT</li> <li>• Field controller with degree of protection IP54</li> <li>• Reliable and easy commissioning and parameterisation with the Festo Configuration Tool (FCT)</li> </ul>	<ul style="list-style-type: none"> <li>• For actuating mini slide SLTE and parallel gripper HGPLE</li> <li>• Easy actuation via I/O interface, PROFIBUS, CANopen, DeviceNet</li> <li>• With or without control panel</li> <li>• Parameterisation via control panel or parameterisation software FCT</li> <li>• For actuating mini slide SLTE, parallel gripper HGPLE</li> <li>• Field controller with degree of protection IP54</li> <li>• Reliable and easy commissioning and parameterisation with the Festo Configuration Tool (FCT)</li> </ul>	<ul style="list-style-type: none"> <li>• End-position controller for the electric short-stroke cylinder ADNE-LAS</li> <li>• No parameterisation necessary as the controller learns everything relevant for the application automatically via a teach function.</li> <li>• Field controller with degree of protection IP65</li> <li>• Simple and quick control via digital I/O modules</li> <li>• Only one cable is required between the short-stroke cylinder and end-position controller.</li> </ul>
→ Page/online	<a href="#">sfc-laci</a>	<a href="#">sfc-dc</a>	<a href="#">cmfl</a>



## Controllers for stepper motors

	 Motor controller CMMO-ST	 Motor controller CMMS-ST	 Motor controller SEC-ST
Type			
Nominal current	5 A		1.25 ... 6 A
Nominal current, load supply	6 A	8 A	
Max. step frequency		4 kHz	40 kHz
Controller operating mode	Cascade controller with PI speed controller, PI current controller, P position controller, PWM MOSFET power end stage	PWM MOSFET power end stage	Bipolar chopper driver
Fieldbus coupling		CANopen, PROFIBUS DP	
Description	<ul style="list-style-type: none"> <li>Motor controller of the Optimised Motion Series (for EPCO, ELGR, ERMO)</li> <li>With convenient FCT commissioning for stepper motor EMMS-ST</li> <li>Simple and quick parameters configuration via web browser and parameter cloud</li> <li>Reliable and easy commissioning and parameterisation with the Festo Configuration Tool (FCT)</li> <li>Simple control via digital I/Os, IO-Link, I-Port, Modbus TCP</li> <li>Safety function Safe Torque Off (STO) PLc</li> <li>Sinusoidal current injection for especially silent motor operation</li> </ul>	<ul style="list-style-type: none"> <li>For controlling stepper motors EMMS-ST and Optimised Motion Series (for EPCO, ELGR, ERMO)</li> <li>Easy and convenient: commissioning and firmware updates via SD card slot</li> <li>Reliable and easy commissioning and parameterisation with the Festo Configuration Tool (FCT)</li> <li>Integrated process interface: digital I/O module, CAN, RS485</li> <li>Optional PROFIBUS and DeviceNet</li> <li>Safety function Safe Torque Off (STO) PLd</li> </ul>	<ul style="list-style-type: none"> <li>Compact unit, ready for installation</li> <li>Current reduction</li> <li>Pre-assembled, electrical connection accessories</li> </ul>
→ Page/online	565	569	sec-st

## Multi-axis controllers

	 Control block CPX-CEC-M1	 Controller CECX-X-M1	 Controller CECX-X-C1
Type			
Operating voltage	21.6 .. 26.4 V DC	19.2 ... 30 VDC	19.2 ... 30 V DC
Operating voltage range DC			
Control interface	CAN bus	CAN bus	CAN bus
Fieldbus coupling	CODESYS Level 2, EasyIP, Modbus TCP, TCP/IP	TCP/IP, EasyIP, Modbus TCP	TCP/IP, EasyIP, Modbus TCP
Supported kinematic systems			
Description	<ul style="list-style-type: none"> <li>Easy actuation of valve terminal configurations</li> <li>Programming with CODESYS to IEC 61131-3</li> <li>Connection to all fieldbuses as a remote controller and for pre-processing</li> <li>Actuation of electric drives via CANopen</li> <li>SoftMotion functions for coordinated multi-axis movements</li> </ul>	<ul style="list-style-type: none"> <li>Motion controller with CODESYS and SoftMotion</li> <li>Programming to standard IEC 61131-3</li> <li>Three plug-in slots for optional modules</li> <li>Optional: communication module for PROFIBUS</li> </ul>	<ul style="list-style-type: none"> <li>Modular master controller with CODESYS</li> <li>Programming to standard IEC 61131-3</li> <li>Three plug-in slots for optional modules</li> <li>Optional: communication module for PROFIBUS</li> </ul>
→ Page/online	<a href="#">cpx-cec-m1</a>	<a href="#">cecx</a>	<a href="#">cecx</a>

## Multi-axis controllers

		
Type	Controller CMXR-C1	Controller CMXR-C2
Operating voltage	24 V DC +20%/15%, 24 V DC +25%/20%	24 V DC +20%/15%, 24 V DC +25%/20%
Operating voltage range DC		
Control interface		
Fieldbus coupling	2 x CANopen masters	2 x CANopen masters
Supported kinematic systems	2-axis gantries X-Z/Y-Z/X-Y, 3-axis gantries X-Y-Z, any interpolation, tripod	2-axis gantries X-Z/Y-Z/X-Y, 3-axis gantries X-Y-Z, any interpolation, tripod
Description	<ul style="list-style-type: none"> <li>• Multi-axis controller for linear and three-dimensional gantries as well as parallel kinematic systems</li> <li>• Optional teach pendant CDSA</li> <li>• Point-to-point and complex path control</li> <li>• Ethernet and CAN Bus interface</li> </ul>	<ul style="list-style-type: none"> <li>• Individual integration in higher-order controllers or simple integration of peripheral devices, e.g. tracking function via vision systems with integrated CODESYS PLC</li> <li>• Ideal for bonding or sealing applications: greater process reliability and quality with defined, speed-independent switching points on the path</li> <li>• Increased flexibility: modular control system for digital and analogue I/O optionally expandable</li> </ul>
→ Page/online	<a href="#">cmxr-c1</a>	<a href="#">cmxr-c2</a>



## Positioner process automation

	
Type	Positioner CMSX
Standard nominal flow rate	50 ... 130 l/min
Ambient temperature	-5 ... 60 °C
Reference value	0 - 10 V, 0 - 20 mA, 4 - 20 mA
Operating pressure	3 ... 8 bar
Safety note	Adjustable, holding, closing, opening
Description	<ul style="list-style-type: none"> <li>• For position control of double-acting pneumatic quarter turn actuators in process automation systems</li> <li>• Simple and efficient position control based on the PID control algorithm</li> <li>• Suitable for quarter turn actuators with a swivel angle of approx. 90° and a mechanical interface in accordance with VDI/VDE Directive 3845</li> <li>• Power supply 24 V DC</li> </ul>
→ Page/online	<a href="#">cmsx</a>

## Safety systems



	
Type	Safety system CMGA-B1, CMGA-E1
Safety function	Encoder Supervisor (ECS), Safe Torque Off (STO), Safely Limited Acceleration (SLA), Safely Limited Speed (SLS), Safely Limited Position (SLP), Safely Limited Increment (SLI), Safe Emergency Limit (SEL), Safe Direction (SDI), Safe Brake Control (SBC), Safe Acceleration Range (SAR), Safe Operating Stop (SOS), Safe Cam (SCA), Safe Stop 1 (SS1), Safe Stop 2 (SS2), suppression, position monitoring (PDM), safe encoder evaluation, safe logic functions
Safety integrity level (SIL)	SIL 3
Encoder interface Input, function	1 proximity sensor, 1 SSI, 1 incr. HTL, 1 incr. TTL, 1 sin/cos, 2 proximity sensors, 2 SSI, 2 incr. HTL, 2 incr. TTL, 2 sin/cos, no
Number of digital logic inputs	12 ... 14
Digital output version	1 safe relay output, 10 safe digital inputs/outputs, 2 signal outputs, 2 pulse outputs, 2 safe digital outputs
Description	<ul style="list-style-type: none"> <li>Basic modules CMGA-B1 and extension modules CMGA-E1: one basic module can actuate max. two extension modules</li> <li>Compact safety system with the option of integrated drive monitoring for one axis</li> <li>For safe processing of emergency stop switches, door monitoring, light curtains, two-hand buttons, enabling buttons, limit switches, displacement encoders</li> <li>Programming software GSPF for creating custom application programs</li> </ul>
→ Page/online	<a href="#">cmga</a>

## Gear units

			
Type	Gear unit EMGA-SST	Gear unit EMGA-EAS	Gear unit EMGA-SAS
Continuous output torque	11 ... 110 Nm	11 ... 110 Nm	11 ... 450 Nm
Max. drive speed	7000 ... 18000 rpm	7000 ... 18000 rpm	7000 ... 18000 rpm
Torsional rigidity	1 ... 6 Nm/arc	1 ... 6 Nm/arc	1 ... 38 Nm/arc
Torsional backlash	0.12 ... 0.25°	0.12 ... 0.25°	0.1 ... 0.25°
Mass moment of inertia of gear unit	0.019 ... 0.77 kgcm <sup>2</sup>	0.019 ... 0.77 kgcm <sup>2</sup>	0.019 ... 12.14 kgcm <sup>2</sup>
Max. efficiency	98%	98%	98%
Description	<ul style="list-style-type: none"> <li>Planetary gear unit for stepper motors EMMS-ST</li> <li>Gear ratio i = 3 and i = 5, available ex-stock</li> <li>Life-time lubrication</li> </ul>	<ul style="list-style-type: none"> <li>Planetary gear unit for servo motors EMMS-AS</li> <li>Gear ratio i = 3 and i = 5, available ex-stock</li> <li>Life-time lubrication</li> </ul>	<ul style="list-style-type: none"> <li>Planetary gear unit for servo motors EMMS-AS</li> <li>Gear ratio i = 3 and i = 5, available ex-stock</li> <li>Life-time lubrication</li> </ul>
→ Page/online	<a href="#">574</a>	<a href="#">577</a>	<a href="#">577</a>



## Power supply units

Type	 Power supply unit CACN	 Power supply unit SVG
Nominal output voltage DC	24 ... 48 V	30.1 V
Nominal output current	5 ... 20 A	4.8 A
Input voltage range AC	100 ... 500 V	100 ... 240 V
Input current	0.9 ... 1.65 A, 1.5 ... 3.0 A, 2.2 ... 1.2 A, 2.3 ... 1.9 A, 5.1 ... 2.3 A	2.1 ... 1.0 A
Power failure buffering	24 ... 110 ms	20 ms
Description	<ul style="list-style-type: none"> <li>• H-rail mounting</li> <li>• Mounting position: free convection</li> </ul>	<ul style="list-style-type: none"> <li>• H-rail mounting</li> <li>• Mounting position: free convection</li> </ul>
→ Page/online	<a href="#">cacn</a>	<a href="#">svg</a>



Overview/Configuration/Ordering  
→ [www.festo.com/catalogue/emme-as](http://www.festo.com/catalogue/emme-as)



Additional information/Support/User documentation  
→ [www.festo.com/sp/emme-as](http://www.festo.com/sp/emme-as)

Servo motors

Servo motors

# EMME-AS



- + Brushless, permanently excited synchronous servo motor
- + Reliable, dynamic, precise
- + Choice of feedback systems: digital absolute displacement encoder in single-turn or multi-turn version
- + Optimised connection technology



- Suitable for motor controller CMMP-AS
- Brushless, permanently excited synchronous servo motors
- Reliable, dynamic, precise
- Digital absolute displacement encoder with single turn (standard), multi-turn (optional)
- Matching gear unit
- ★ Quick ordering of basic designs → 527

→ [www.festo.com/catalogue/emme-as](http://www.festo.com/catalogue/emme-as)

**Product range overview**

Motor flange size	Nominal voltage [V AC]	Nominal torque [Nm]	With gear unit	With brake
40	360	0.12 ... 0.21	■	■
60	360	0.6 ... 1.2	■	■
80	360, 565	2.3 ... 3.2	■	■
100	565	4.8 ... 6.4	■	■

**Product options**

- |   |        |    |                              |   |                               |   |       |
|---|--------|----|------------------------------|---|-------------------------------|---|-------|
| S | Short  | LS | Low-voltage, standard        | A | Angled plug                   | B | Brake |
| M | Medium | LV | Low-voltage, speed-optimised | S | Absolute encoder, single turn |   |       |
|   |        | HS | High-voltage, standard       | M | Absolute encoder, multi-turn  |   |       |

## Data sheet

4



Technical data										Dimensions → 529	
Motor flange size		40		60		80				100	
Length		S	M	S	M	S	M	S	M	S	M
Winding		LV	LV	LS	LS	LS	HS	LS	HS	HS	HS
Nominal voltage	[V AC]	360	360	360	360	360	565	360	565	565	565
Nominal current	[A]	0.7	1.2	0.8	1.5	2.6	1.6	3.7	2.1	3.0	4.1
Continuous current at standstill		0.8	1.6	0.9	1.8	3.1	1.8	3.9	2.2	3.4	4.6
Peak current	[A]	3.2	6.4	3.6	7.2	12.4	7.2	15.6	8.8	13.6	18.4
Rated output	[W]	110	200	190	380	750	720	1000	1000	1500	2000
Nominal torque	[Nm]	0.12	0.21	0.6	1.2	2.4	2.3	3.2	3.2	4.8	6.4
Peak torque	[Nm]	0.7	1.4	2.8	6.0	11.2	11.2	14.0	14.0	22.4	30.0
Torque at standstill	[Nm]	0.18	0.35	0.7	1.5	2.8	2.8	3.5	3.5	5.6	7.5
Nominal rotary speed	[rpm]	9000	9000	3000	3000	3000	3000	3000	3000	3000	3000
Max. rotational speed	[rpm]	10000	10000	5131	4925	4690	4192	4627	4097	3910	3941
Brake											
Operating voltage	[V DC]	24 +6 ... -10%									
Holding torque	[Nm]	0.4		2.0		4.5		9.0			

Technical data – Encoder		
Measuring unit		EMME-AS-...-...S... Absolute, single turn (SEK 34/37)
		EMME-AS-...-...M... Absolute, multi-turn (SEL 34/37)
Operating voltage	[V DC]	7 ... 12 (±5%)
Interface signals/Protocol – HIPERFACE®		
Process data channel		SIN, REFSIN, COS, REFCOS (analogue differential)
Measuring principle		Capacitive
Sinusoidal/Cosinusoidal periods per revolution		16
Parameter channel		RS485 (digital)
Absolute position values per revolution		512 (resolution 9 bits)
Max. rotational speed		
For absolute value generation	[rpm]	6000
Mechanical	[rpm]	12000
Revolutions		1
		4096 revolutions, 12 bits
Interpolation of sine/cosine signals in the motor controller <sup>1)</sup>		
Measurement step at 12 bits		20" (angular seconds)
Angular accuracy		±20' (angular minutes)

1) Dependent on the motor controller.

Operating conditions	
Ambient temperature	[°C] -10 ... +40 (up to 100 °C with derating of 1.5% per degree Celsius)
Degree of protection	
Motor shaft	IP21
Motor shaft and connection technology	IP65
Insulation class	F (155 °C)
Rated class acc. to EN 60034-1	S1 (continuous operation)
Thermal class acc. to EN 60034-1	F (155 °C)

**Data sheet**

Torque M as a function of rotational speed n

Flange size 40

Length S

Winding LV

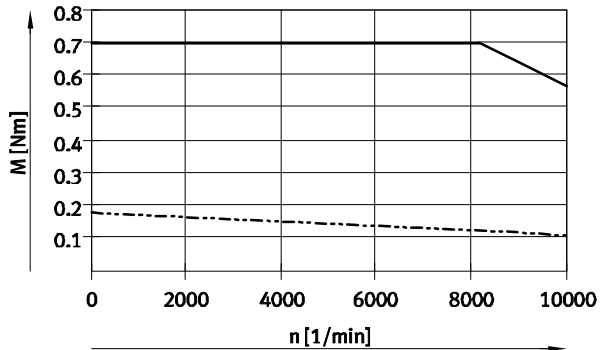

Length M

Winding LV

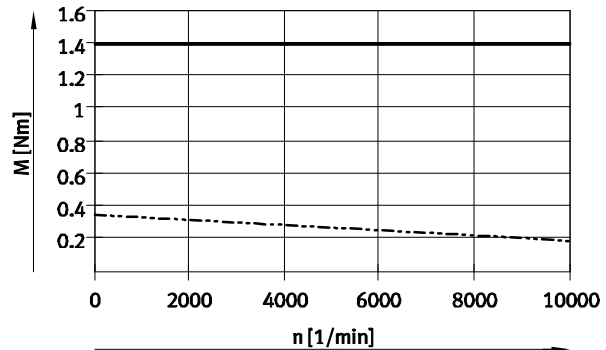

Flange size 60

Length S

Winding LS

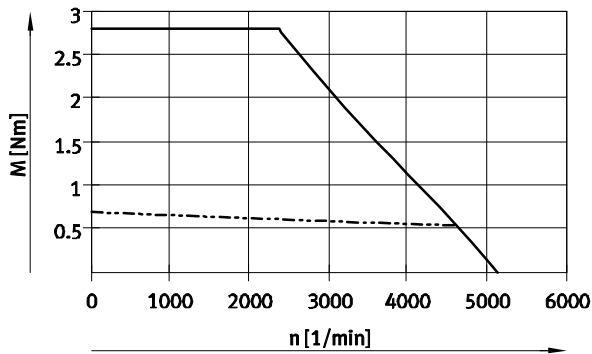

Length M

Winding LS

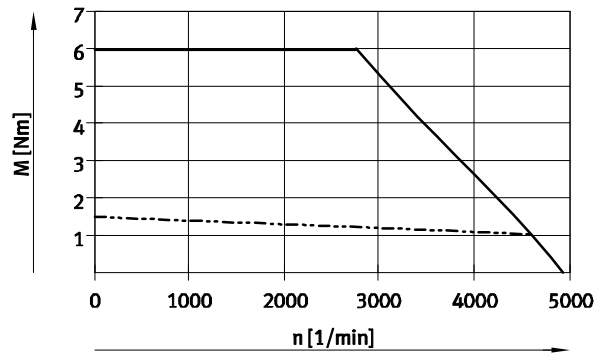

— Peak torque  
 - - - Nominal torque

**Note**

Typical motor characteristic curve with nominal voltage and optimal motor controller.

## Data sheet

Torque M as a function of rotational speed n

Flange size 80

Length S

Winding LS

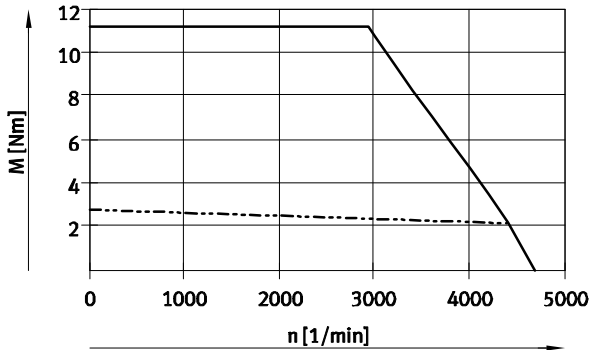

Length S

Winding HS

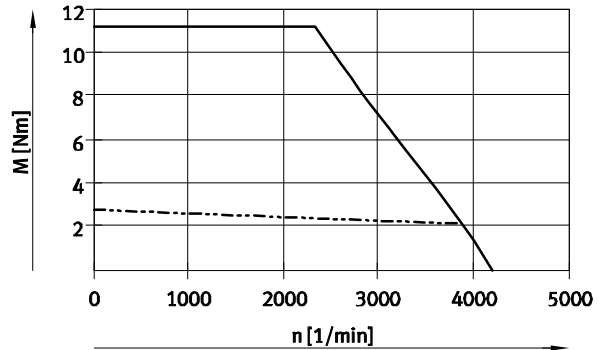

Length M

Winding LS

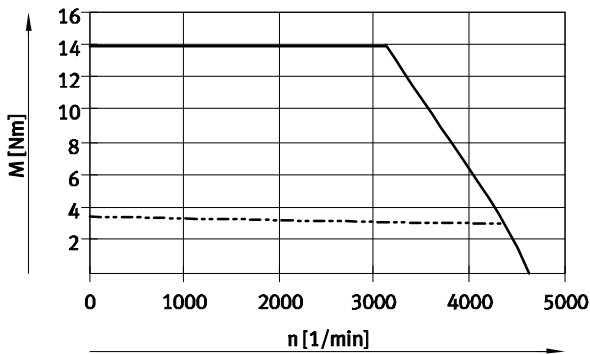

Length M

Winding HS

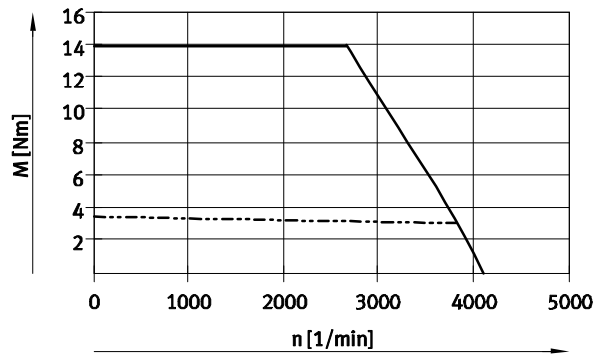

Flange size 100

Length S

Winding HS

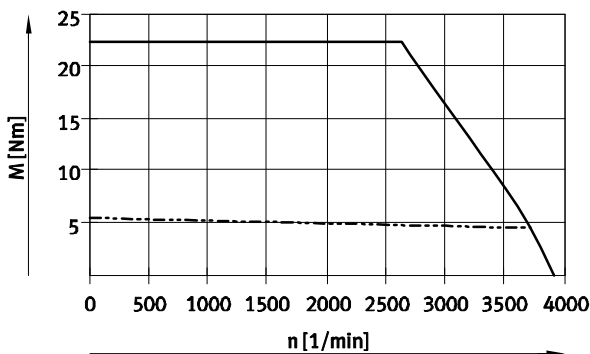

Length M

Winding HS

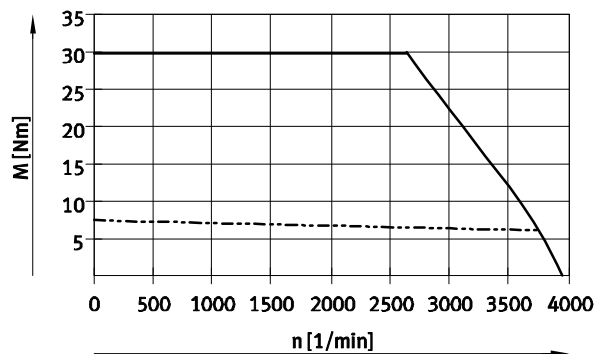

— Peak torque  
 - - - Nominal torque

### Note

Typical motor characteristic curve with nominal voltage and optimal motor controller.

**Ordering code – Flange size 40**

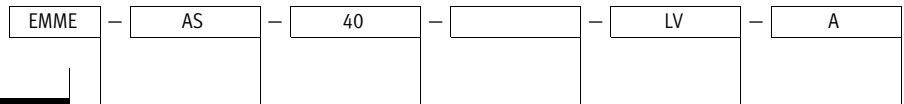

<b>Type</b>	
EMME	Motor
<b>Motor type</b>	
AS	Servo motor
<b>Motor flange size</b>	
40	40 mm
<b>Length</b>	
S	Short
M	Medium
<b>Winding</b>	
LV	Low-voltage, speed optimised
<b>Electrical connection</b>	
A	Angled plug, fixed – outlet direction: shaft
<b>Measuring unit</b>	
S	Absolute encoder, single turn
M	Absolute encoder, multi-turn
<b>Brake</b>	
–	Without
B	With brake

**Order example:**

EMME-AS-40-M-LV-ASB

Motor EMME - servo motor - flange size 40 - length: medium - winding: low-voltage, speed-optimised - angled plug - measuring unit: absolute encoder, single turn - with brake

## Ordering code – Flange size 60

EMME		–	AS		–	60		–		–	LS		–	A	
<b>Type</b>															
EMME		Motor													
<b>Motor type</b>															
AS		Servo motor													
<b>Motor flange size</b>															
60		60 mm													
<b>Length</b>															
S		Short													
M		Medium													
<b>Winding</b>															
LS		Low-voltage, standard													
<b>Electrical connection</b>															
A		Angled plug, fixed – outlet direction: shaft													
<b>Measuring unit</b>															
S		Absolute encoder, single turn													
M		Absolute encoder, multi-turn													
<b>Brake</b>															
–		Without													
B		With brake													

**Order example:**

EMME-AS-60-M-LS-ASB

Motor EMME - servo motor - flange size 60 - length: medium - winding: low-voltage, standard - angled plug - measuring unit: absolute encoder, single turn - with brake



Ordering code – Flange size 80

EMME – AS – 80 – – – A

<b>Type</b>	
EMME	Motor
<b>Motor type</b>	
AS	Servo motor
<b>Motor flange size</b>	
80	80 mm
<b>Length</b>	
S	Short
M	Medium
<b>Winding</b>	
LS	Low-voltage, standard
HS	High-voltage, standard
<b>Electrical connection</b>	
A	Angled plug, fixed – outlet direction: shaft
<b>Measuring unit</b>	
S	Absolute encoder, single turn
M	Absolute encoder, multi-turn
<b>Brake</b>	
–	Without
B	With brake

**Order example:**

EMME-AS-80-M-LS-ASB

Motor EMME - servo motor - flange size 80 - length: medium - winding: low-voltage, standard - angled plug - measuring unit: absolute encoder, single turn - with brake

## Ordering code – Flange size 100

EMME		–	AS		–	100		–		–	HS		–	A	
<b>Type</b>															
EMME		Motor													
<b>Motor type</b>															
AS		Servo motor													
<b>Motor flange size</b>															
100		100 mm													
<b>Length</b>															
S		Short													
M		Medium													
<b>Winding</b>															
HS		High-voltage, standard													
<b>Electrical connection</b>															
A		Angled plug, fixed – outlet direction: shaft													
<b>Measuring unit</b>															
S		Absolute encoder, single turn													
M		Absolute encoder, multi-turn													
<b>Brake</b>															
–		Without													
B		With brake													

**Order example:**

EMME-AS-100-M-HS-ASB

Motor EMME - servo motor - flange size 100 - length: medium - winding: high-voltage, standard - angled plug - measuring unit: absolute encoder, single turn - with brake

★ Quick ordering<sup>1)</sup>

Part no.	Type
<b>Flange size 40, length: short</b>	
2082428	EMME-AS-40-S-LV-AS
2082430	EMME-AS-40-S-LV-ASB
2082429	EMME-AS-40-S-LV-AM
2082431	EMME-AS-40-S-LV-AMB
<b>Flange size 40, length: medium</b>	
2082444	EMME-AS-40-M-LV-AS
2082446	EMME-AS-40-M-LV-ASB
2082445	EMME-AS-40-M-LV-AM
2082447	EMME-AS-40-M-LV-AMB
<b>Flange size 60, length: short</b>	
2089698	EMME-AS-60-S-LS-AS
2089700	EMME-AS-60-S-LS-ASB
2089699	EMME-AS-60-S-LS-AM
2089701	EMME-AS-60-S-LS-AMB
<b>Flange size 60, length: medium</b>	
2089730	EMME-AS-60-M-LS-AS
2089732	EMME-AS-60-M-LS-ASB
2089731	EMME-AS-60-M-LS-AM
2089733	EMME-AS-60-M-LS-AMB

Part no.	Type
<b>Flange size 80, length: short</b>	
2093104	EMME-AS-80-S-LS-AS
2093106	EMME-AS-80-S-LS-ASB
2093105	EMME-AS-80-S-LS-AM
2093107	EMME-AS-80-S-LS-AMB
2093136	EMME-AS-80-S-HS-AS
2093138	EMME-AS-80-S-HS-ASB
2093137	EMME-AS-80-S-HS-AM
2093139	EMME-AS-80-S-HS-AMB
<b>Flange size 80, length: medium</b>	
2093168	EMME-AS-80-M-LS-AS
2093170	EMME-AS-80-M-LS-ASB
2093169	EMME-AS-80-M-LS-AM
2093171	EMME-AS-80-M-LS-AMB
2093200	EMME-AS-80-M-HS-AS
2093202	EMME-AS-80-M-HS-ASB
2093201	EMME-AS-80-M-HS-AM
2093203	EMME-AS-80-M-HS-AMB

Part no.	Type
<b>Flange size 100, length: short</b>	
2103467	EMME-AS-100-S-HS-AS
2103469	EMME-AS-100-S-HS-ASB
2103468	EMME-AS-100-S-HS-AM
2103470	EMME-AS-100-S-HS-AMB
<b>Flange size 100, length: medium</b>	
2103499	EMME-AS-100-M-HS-AS
2103501	EMME-AS-100-M-HS-ASB
2103500	EMME-AS-100-M-HS-AM
2103502	EMME-AS-100-M-HS-AMB

1) All products in this table are easy to select and quick to order.

**Ordering – Product options**



**Configurable product**

**This product and all its options can be ordered using the configurator.**

The configurator can be found under Products on the DVD or  
 → [www.festo.com/catalogue/...](http://www.festo.com/catalogue/...)

Enter the type code in the search field.

## Accessories – Ordering data

## Motor cable

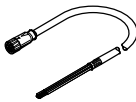
	Cable length [m]		Part no.	Type
<b>for EMME-AS-40/60 (cable cross section: 0.75 mm<sup>2</sup>)</b>				
	2.5	★	8004662	NEBM-M16G8-E-2.5-Q7-LE8
	5.0	★	8003770	NEBM-M16G8-E-5-Q7-LE8
	7.5	★	8004663	NEBM-M16G8-E-7.5-Q7-LE8
	10.0	★	8003771	NEBM-M16G8-E-10-Q7-LE8
	15.0	★	8003772	NEBM-M16G8-E-15-Q7-LE8
	X length <sup>1)</sup>		8003773	NEBM-M16G8-E--Q7-LE8
<b>for EMME-AS-80/100 (cable cross section: 1.5 mm<sup>2</sup>)</b>				
	2.5	★	8004660	NEBM-M16G8-E-2.5-Q9-LE8
	5.0	★	8003766	NEBM-M16G8-E-5-Q9-LE8
	7.5	★	8004661	NEBM-M16G8-E-7.5-Q9-LE8
	10.0	★	8003767	NEBM-M16G8-E-10-Q9-LE8
	15.0	★	8003768	NEBM-M16G8-E-15-Q9-LE8
	X length <sup>1)</sup>		8003769	NEBM-M16G8-E--Q9-LE8

1) Max. 25 m. Cable lengths > 25 m possible following technical clarification; up to 100 m on request.  
Available in Q1 m increments.

## Encoder cable

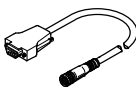
	Cable length [m]		Part no.	Type
<b>for EMME-AS-40/60/80/100</b>				
	2.5	★	8004664	NEBM-M12G8-E-2.5-N-S1G15
	5.0	★	8003762	NEBM-M12G8-E-5-N-S1G15
	7.5	★	8004665	NEBM-M12G8-E-7.5-N-S1G15
	10.0	★	8003763	NEBM-M12G8-E-10-N-S1G15
	15.0	★	8003764	NEBM-M12G8-E-15-N-S1G15
	X length <sup>1)</sup>		8003765	NEBM-M12G8-E--N-S1G15

1) Max. 25 m. Cable lengths > 25 m possible following technical clarification; up to 100 m on request.  
Available in Q1 m increments.

**Dimensions**

Download CAD data → [www.festo.com](http://www.festo.com)

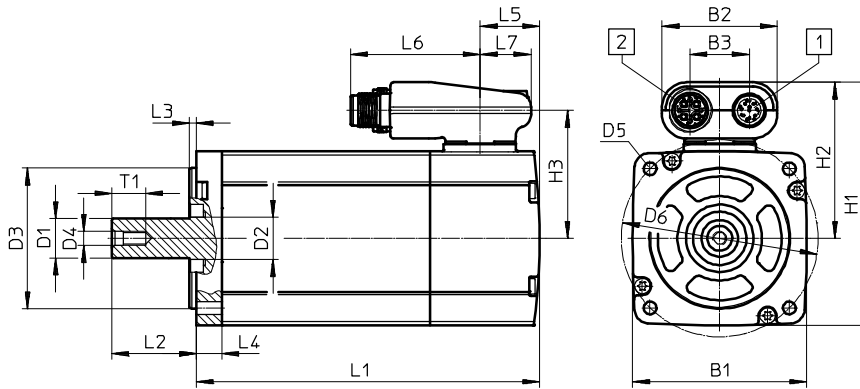

- 1 Encoder cable
- 2 Motor cable

Flange size	Length	B1	B2	B3	D1 ∅ h6	D2 ∅	D3 ∅ h7	D4
40	S	40	41	21	8	10	30	M3
	M							
60	S	62	41	21	14	15	50	M5
	M							
80	S	82	41	21	19	20	70	M6
	M							
100	S	102	41	21	19	25	95	M6
	M							

Flange size	Length	D5 ∅	D6 ∅ ±0.3	H1	H2	H3	L1	
							±2	With brake ±2
40	S	3.4	45	68.5	48.5	38.5	89	124
	M						114	149
60	S	4.5	70	86.5	55.5	45.5	122	156
	M						152	186
80	S	5.5	90	106.5	65.5	55.5	158	200
	M						178	220
100	S	9	115	126.5	75.5	65.5	200	242
	M						225	267

Flange size	Length	L2	L3 ±0.2	L4 ±0.3	L5	L6	L7	T1
40	S	20 <sup>+0,5/-0,7</sup>	2.5	4.5	25.3	46.2	18	9
	M							
60	S	30 <sup>+0,5/-0,2</sup>	2.5	9	21	46.2	18	12.5
	M							
80	S	35 <sup>+0,4/-0,2</sup>	3	10	23	46.2	18	16
	M							
100	S	40 <sup>+0,4/-0,2</sup>	3	12	25.5	46.2	18	16
	M							



Overview/Configuration/Ordering  
→ [www.festo.com/catalogue/emms-as](http://www.festo.com/catalogue/emms-as)



Additional information/Support/User documentation  
→ [www.festo.com/sp/emms-as](http://www.festo.com/sp/emms-as)

Servo motors

Servo motors

# EMMS-AS



- + Servo motor: permanently excited, electrodynamic, brushless
- + Digital absolute displacement encoder in single-turn or multi-turn version
- + Optionally with holding brake
- + Optimised connection technology



- Suitable for motor controller CMMP-AS
- Brushless, permanently excited synchronous servo motors
- Digital absolute displacement encoder with single turn (standard), multi-turn (optional)
- No homing after voltage failure
- Matching gear unit

→ [www.festo.com/catalogue/emms-as](http://www.festo.com/catalogue/emms-as)

### Product range overview

Motor flange size	Nominal voltage [V AC]	Nominal torque [Nm]	With gear unit	With brake
40	360	0.14 ... 0.22	■	■
55	360, 565	0.31 ... 0.68	■	■
70	360, 565	1.37 ... 2.29	■	■
100	565	3.24 ... 7.51	■	■
140	565	9.55 ... 21.12	■	■
190	565	17.47 ... 22.63	■	■

### Product options

S	Short	LS	Low-voltage, standard	A	Angled plug	S	Absolute encoder, single turn
M	Medium	LV	Low-voltage, speed-optimised	R	Angled plug, rotatable	M	Absolute encoder, multi-turn
L	Long	HS	High-voltage, standard	S	Straight plug	R	Resolver
K	Shaft acc. to DIN 6885 with feather key	HV	High-voltage, speed-optimised	T	Terminal box	B	Brake
						S1	IP65 (with shaft sealing ring)

## Data sheet



4

Technical data		Dimensions → 545									
Motor flange size		40		55				70			
Length		S	M	S	S	M	M	S	S	S	S
Winding		LS	LS	LS	HS	LS	HS	LS	LV	HS	HV
Nominal voltage	[V AC]	360	360	360	565	360	565	360	360	565	565
Nominal current	[A]	0.83	0.63	0.83	0.49	1.19	0.80	2.20	2.64	1.29	1.60
Peak current	[A]	3.3	3.3	4.30	2.70	5	4.90	5	11	5.90	7.50
Rated output	[W]	135	232	261	246	461	470	866	945	794	992
Nominal torque	[Nm]	0.14	0.22	0.34	0.31	0.67	0.68	1.43	1.37	1.31	1.28
Peak torque	[Nm]	0.5	1	1.65	1.62	2.7	3.8	3.10	5	5.17	5.17
Standstill torque	[Nm]	0.16	0.26	0.49	0.46	0.97	0.99	1.64	1.64	1.50	1.62
Nominal rotary speed	[rpm]	9000	10300	7400	7600	6600	6600	5300	6600	5800	7400
Max. rotational speed	[rpm]	23040	11520	9800	9840	7330	7750	6450	8070	6460	8200
Brake											
Operating voltage	[V DC]	24 +6 ... -10%									
Holding torque	[Nm]	0.4		0.8				2			

Flange size		70				100			
Length		M	M	M	M	S	M	L	L
Winding		LS	LV	HS	HV	HS	HS	HS	HV
Nominal voltage	[V AC]	360	360	565	565	565	565	565	565
Nominal current	[A]	2.60	3.02	1.70	1.84	3.30	3.40	3.80	3.79
Peak current	[A]	10	12.50	7.40	8.30	15	15	24.80	24.80
Rated output	[W]	1061	1100	1044	1146	1560	2000	2360	2240
Nominal torque	[Nm]	2.29	2.28	2.26	2.19	3.24	5.63	7.51	6.29
Peak torque	[Nm]	7.75	8.30	8.55	8.55	12.50	22.10	39.80	35.40
Standstill torque	[Nm]	2.56	2.57	2.53	2.52	4.71	8.01	10.94	10.93
Nominal rotary speed	[rpm]	4100	4600	4400	5000	4600	3400	3000	3400
Max. rotational speed	[rpm]	4880	5570	4960	5560	6680	4030	3360	4040
Brake									
Operating voltage	[V DC]	24 +6 ... -10%							
Holding torque	[Nm]	2				9			

Flange size		140				190	
Length		S	S	L	L	S	M
Winding		HS	HV	HS	HV	HS	HS
Nominal voltage	[V AC]	565	565	565	565	565	565
Nominal current	[A]	4.40	5.23	7.80	9.96	14.43	14.24
Peak current	[A]	15	24.40	20	51.50	77.20	88.20
Rated output	[W]	2600	3140	4420	5110	5490	6880
Nominal torque	[Nm]	9.55	7.70	21.12	17.41	17.47	22.63
Peak torque	[Nm]	25.60	27	48.80	67.50	80	120
Standstill torque	[Nm]	11.20	11.08	25.60	25.50	26.20	38.77
Nominal rotary speed	[rpm]	2600	3900	2000	2800	3000	2900
Max. rotational speed	[rpm]	3060	4510	2460	3830	5300	4060
Brake							
Operating voltage	[V DC]	24 +6 ... -10%					
Holding torque	[Nm]	18				30	



**Data sheet**

<b>Technical data – Encoder</b>		
Type	EMMS-AS-...-...S...	EMMS-AS-...-...M...
	Absolute, single turn	Absolute, multi-turn
Operating voltage [V DC]	5	
Protocol	EnDat 2.1, digital channel only, max. cycle rate (CLOCK) 2 MHz	
Position values per revolution	262 144	
Resolution	18 bit	
	-	4096 revolutions, 12 bits

<b>Technical data – Resolver</b>		
Version	Transmitter	
Input voltage [V DC]	4	
Input current [mA]	50	
Number of poles	2	
Carrier frequency [kHz]	3.4 ... 8.0	

<b>Operating conditions</b>		Encoder	Resolver
Ambient temperature [°C]		-10 ... +40 (up to 100 °C with derating)	-40 ... +40 (up to 130 °C with derating)
Degree of protection			
Motor shaft		IP54	
Motor housing incl. connection technology		IP65	
With shaft sealing ring		IP65	
Insulation class		F	
Rated class acc. to EN 60034-1		S1	
Thermal class acc. to EN 60034-1		F	

## Data sheet

Torque M as a function of rotational speed n

Flange size 40

Length S

Winding LS

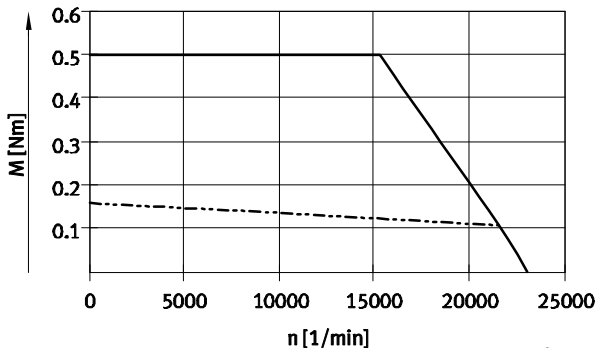

Length M

Winding LS

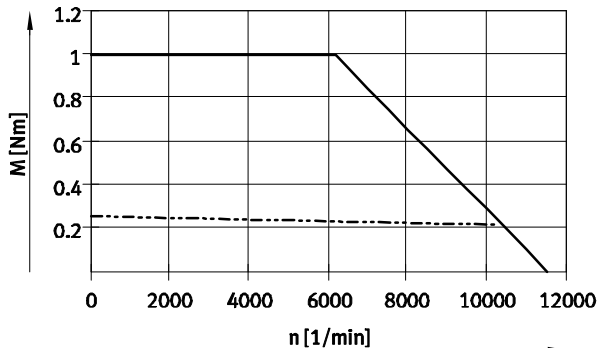

Flange size 55

Length S

Winding LS

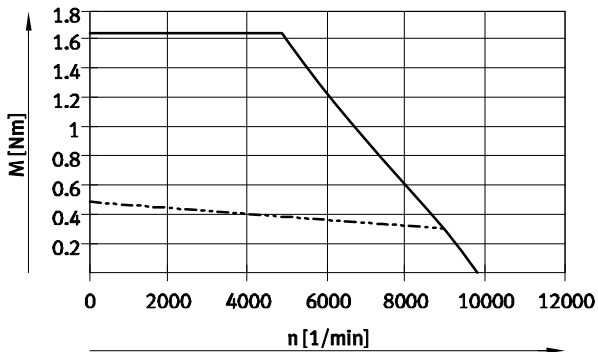

Length S

Winding HS

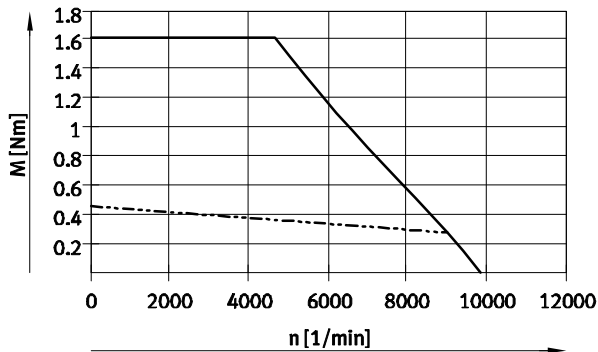

Length M

Winding LS

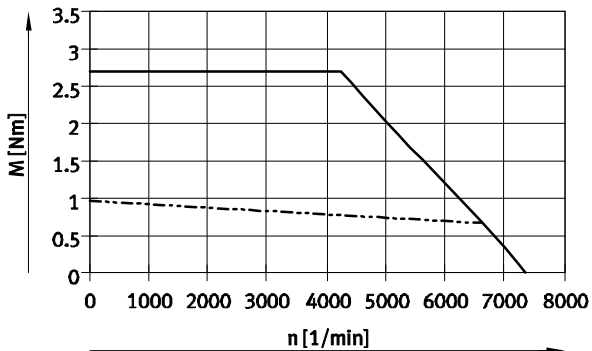

Length M

Winding HS

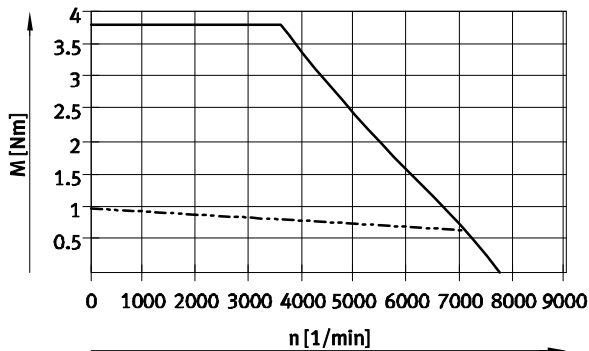

— Peak torque  
 - - - Nominal torque

**Note**

Typical motor characteristic curve with nominal voltage and optimal motor controller.

**Data sheet**

**Torque M as a function of rotational speed n**

Flange size 70

Length S

Winding LS, LV

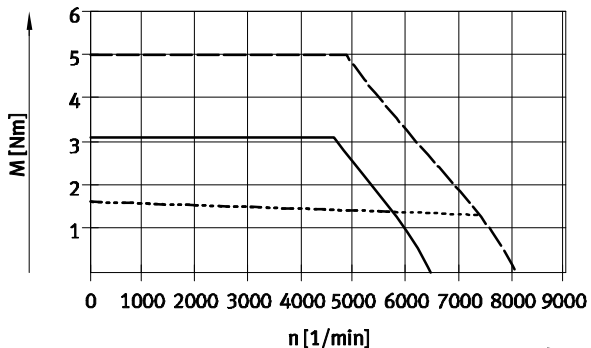

- Peak torque EMMS-AS-...-LS
- - - - Nominal torque EMMS-AS-...-LS
- - - - Peak torque EMMS-AS-...-LV
- ..... Nominal torque EMMS-AS-...-LV

Length S

Winding HS, HV

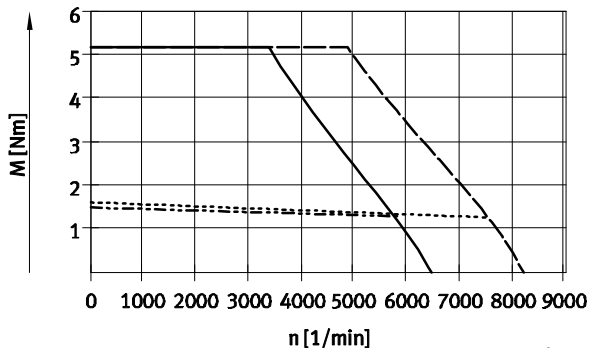

- Peak torque EMMS-AS-...-HS
- - - - Nominal torque EMMS-AS-...-HS
- - - - Peak torque EMMS-AS-...-HV
- ..... Nominal torque EMMS-AS-...-HV

Length M

Winding LS, LV

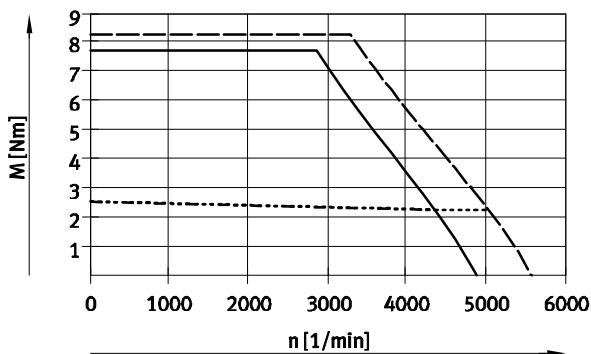

- Peak torque EMMS-AS-...-LS
- - - - Nominal torque EMMS-AS-...-LS
- - - - Peak torque EMMS-AS-...-LV
- ..... Nominal torque EMMS-AS-...-LV

Length M

Winding HS, HV

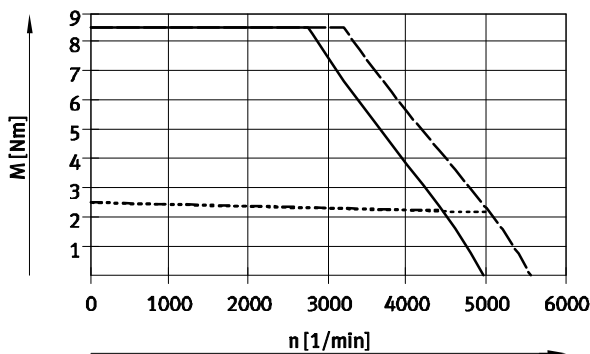

- Peak torque EMMS-AS-...-HS
- - - - Nominal torque EMMS-AS-...-HS
- - - - Peak torque EMMS-AS-...-HV
- ..... Nominal torque EMMS-AS-...-HV

**Note**

Typical motor characteristic curve with nominal voltage and optimal motor controller.

## Data sheet

Torque M as a function of rotational speed n

Flange size 100

Length S

Winding HS

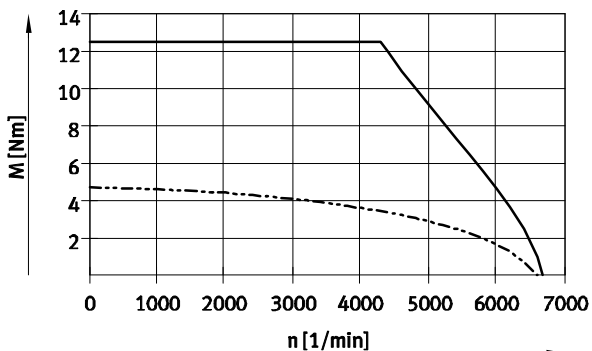

Length M

Winding HS

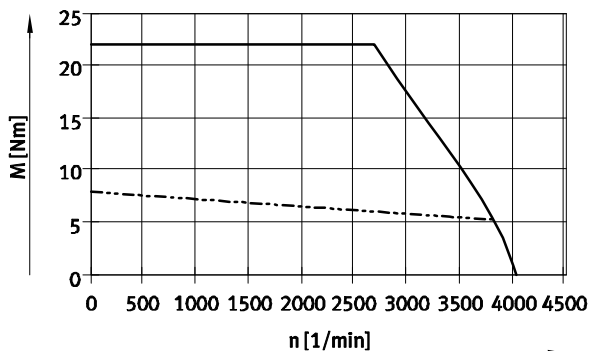

Length L

Winding HS

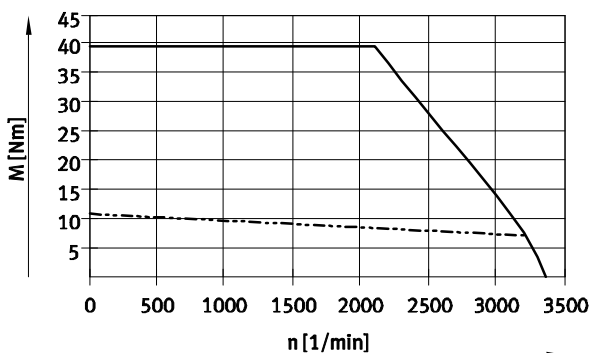

Length L

Winding HV

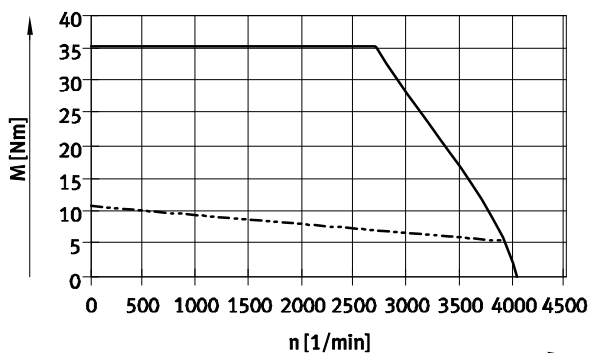

Flange size 140

Length S

Winding HS

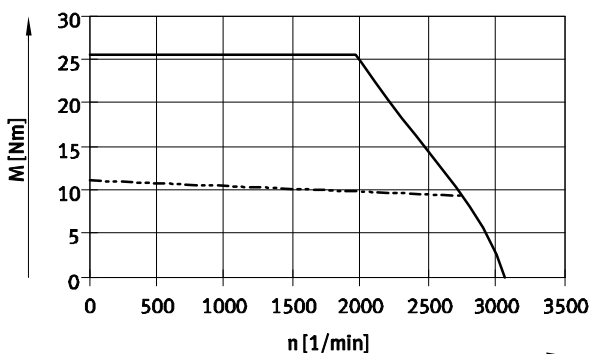

Length S

Winding HV

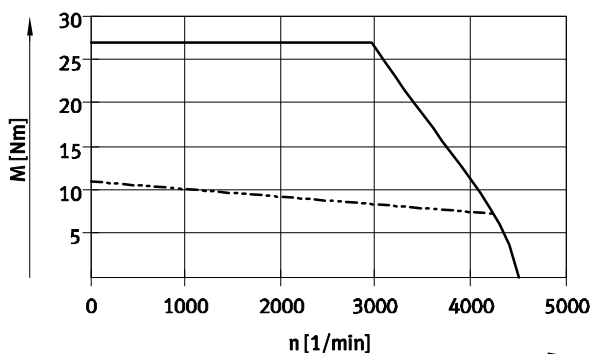

— Peak torque  
 - - - Nominal torque

**Note**

Typical motor characteristic curve with nominal voltage and optimal motor controller.

**Data sheet**

Torque M as a function of rotational speed n

Flange size 140

Length L

Winding HS

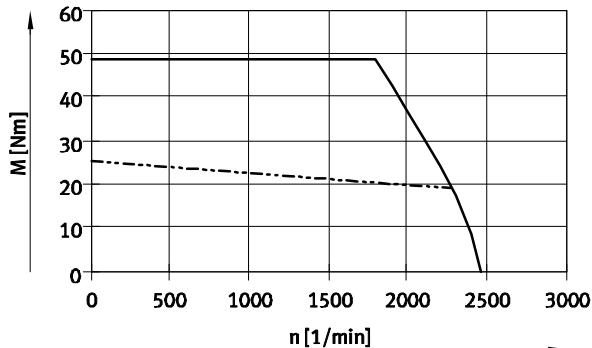

Length L

Winding HV

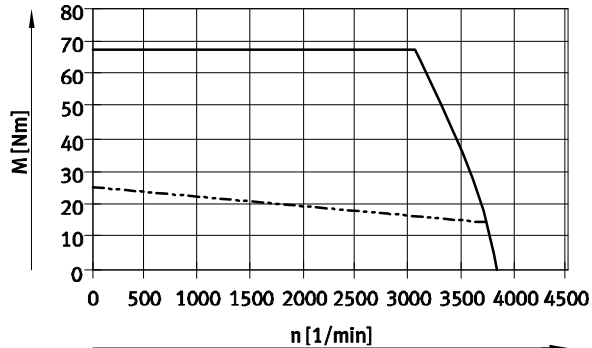

Flange size 190

Length S

Winding HS

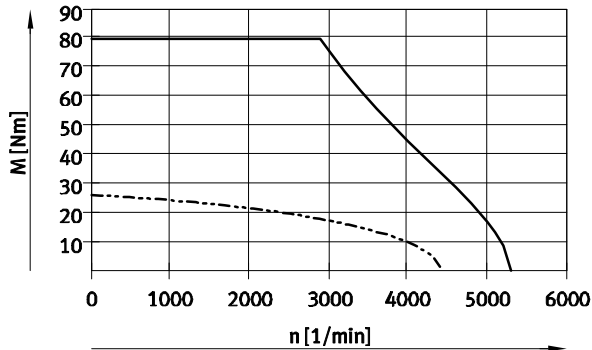

Length M

Winding HS

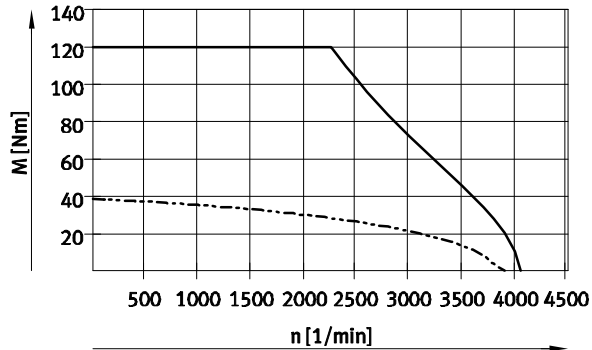

— Peak torque  
 - - - Nominal torque

**Note**

Typical motor characteristic curve with nominal voltage and optimal motor controller.

## Ordering code – Flange size 40

EMMS		AS	40		LS	
<b>Type</b>						
EMMS	Motor					
<b>Motor type</b>						
AS	Servo motor					
<b>Motor flange size</b>						
40	40 mm					
<b>Length</b>						
S	Short					
M	Medium					
<b>Output shaft</b>						
-	Smooth shaft					
K	Shaft acc. to DIN 6885 (with feather key)					
<b>Winding</b>						
LS	Low-voltage, standard					
<b>Electrical connection</b>						
S	Straight plug					
T	Terminal box					
<b>Measuring unit</b>						
S	Absolute encoder, single turn					1
M	Absolute encoder, multi-turn					1
R	Resolver					2
<b>Brake</b>						
-	Without					
B	With brake					

1 Only with electrical connection T.

2 Only with electrical connection S.

**Order example:**

EMMS-AS-40-M-LS-TSB

Motor EMMS - servo motor - flange size 40 - length: medium - output shaft: smooth shaft - winding: low-voltage, standard - electrical connection: terminal box - measuring unit: absolute encoder, single turn - with brake

Ordering code – Flange size 55

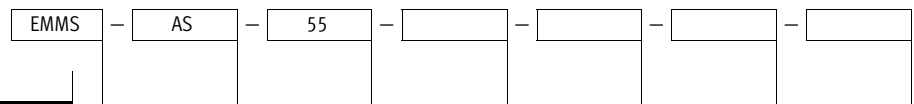

Type	
EMMS	Motor

Motor type	
AS	Servo motor

Motor flange size	
55	55 mm

Length	
S	Short
M	Medium

Output shaft	
–	Smooth shaft
K	Shaft acc. to DIN 6885 (with feather key)

Winding	
LS	Low-voltage, standard
HS	High-voltage, standard

Electrical connection	
R	Angled plug, rotatable
T	Terminal box

Measuring unit	
S	Absolute encoder, single turn <span style="border: 1px solid black; padding: 0 2px;">1</span>
M	Absolute encoder, multi-turn <span style="border: 1px solid black; padding: 0 2px;">1</span>
R	Resolver <span style="border: 1px solid black; padding: 0 2px;">2</span>

Brake	
–	Without
B	With brake

Degree of protection	
–	Standard
S1	IP65 (with shaft sealing ring)

1 Only with electrical connection T.

2 Only with electrical connection R.

**Order example:**

EMMS-AS-55-M-LS-TSB

Motor EMMS - servo motor - flange size 55 - length: medium - output shaft: smooth shaft - winding: low-voltage, standard - electrical connection: terminal box - measuring unit: absolute encoder, single turn - with brake

## Ordering code – Flange size 70

EMMS		–	AS		–	70		–		–		–		–	
<b>Type</b>															
EMMS	Motor														
<b>Motor type</b>															
AS	Servo motor														
<b>Motor flange size</b>															
70	70 mm														
<b>Length</b>															
S	Short														
M	Medium														
<b>Output shaft</b>															
–	Smooth shaft														
K	Shaft acc. to DIN 6885 (with feather key)														
<b>Winding</b>															
LS	Low-voltage, standard														
LV	Low-voltage, speed optimised														
HS	High-voltage, standard														
HV	High-voltage, speed-optimised														
<b>Electrical connection</b>															
R	Angled plug, rotatable														
<b>Measuring unit</b>															
S	Absolute encoder, single turn														
M	Absolute encoder, multi-turn														
R	Resolver														
<b>Brake</b>															
–	Without														
B	With brake														
<b>Degree of protection</b>															
–	Standard														
S1	IP65 (with shaft sealing ring)														

**Order example:**

EMMS-AS-70-M-LS-RSB

Motor EMMS - servo motor - flange size 70 - length: medium - output shaft: smooth shaft - winding: low-voltage, standard - electrical connection: angled plug, rotatable - measuring unit: absolute encoder, single turn - with brake - degree of protection: standard



Ordering code – Flange size 100

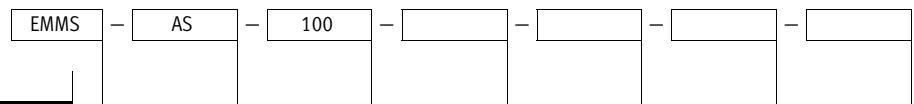

<b>Type</b>	
EMMS	Motor
<b>Motor type</b>	
AS	Servo motor
<b>Motor flange size</b>	
100	100 mm
<b>Length</b>	
S	Short
M	Medium
L	Long
<b>Output shaft</b>	
–	Smooth shaft
K	Shaft acc. to DIN 6885 (with feather key)
<b>Winding</b>	
HS	High-voltage, standard
HV	High-voltage, speed-optimised <sup>1</sup>
<b>Electrical connection</b>	
R	Angled plug, rotatable
<b>Measuring unit</b>	
S	Absolute encoder, single turn
M	Absolute encoder, multi-turn
R	Resolver
<b>Brake</b>	
–	Without
B	With brake
<b>Degree of protection</b>	
–	Standard
S1	IP65 (with shaft sealing ring)

<sup>1</sup> Only with length L.

**Order example:**

EMMS-AS-100-M-HS-RSB

Motor EMMS - servo motor - flange size 100 - length: medium - output shaft: smooth shaft - winding: high-voltage, standard - electrical connection: angled plug, rotatable - measuring unit: absolute encoder, single turn - with brake - degree of protection: standard

## Ordering code – Flange size 140

		EMMS	–	AS	–	140	–		–		–		–		
<b>Type</b>															
EMMS	Motor														
<b>Motor type</b>															
AS	Servo motor														
<b>Motor flange size</b>															
140	140 mm														
<b>Length</b>															
S	Short														
L	Long														
<b>Output shaft</b>															
–	Smooth shaft														
K	Shaft acc. to DIN 6885 (with feather key)														
<b>Winding</b>															
HS	High-voltage, standard														
HV	High-voltage, speed-optimised														
<b>Electrical connection</b>															
R	Angled plug, rotatable														
<b>Measuring unit</b>															
S	Absolute encoder, single turn														
M	Absolute encoder, multi-turn														
R	Resolver														
<b>Brake</b>															
–	Without														
B	With brake														
<b>Degree of protection</b>															
–	Standard														
S1	IP65 (with shaft sealing ring)														

**Order example:**

EMMS-AS-140-L-HS-RSB

Motor EMMS - servo motor - flange size 140 - length: long - output shaft: smooth shaft - winding: high-voltage, standard - electrical connection: angled plug, rotatable - measuring unit: absolute encoder, single turn - with brake - degree of protection: standard

**Ordering code – Flange size 190**

		EMMS	–	AS	–	190	–		–		–		–	
<b>Type</b>														
EMMS	Motor													
<b>Motor type</b>														
AS	Servo motor													
<b>Motor flange size</b>														
190	190 mm													
<b>Length</b>														
S	Short													
M	Medium													
<b>Output shaft</b>														
–	Smooth shaft													
K	Shaft acc. to DIN 6885 (with feather key)													
<b>Winding</b>														
HS	High-voltage, standard													
<b>Electrical connection</b>														
A	Angled plug													
<b>Measuring unit</b>														
S	Absolute encoder, single turn													
M	Absolute encoder, multi-turn													
R	Resolver													
<b>Brake</b>														
–	Without													
B	With brake													
<b>Degree of protection</b>														
–	Standard													
S1	IP65 (with shaft sealing ring)													

**Order example:**

EMMS-AS-190-M-HS-ASB



Motor EMMS - servo motor - flange size 190 - length: medium - output shaft: smooth shaft - winding: high-voltage, standard - electrical connection: angled plug - measuring unit: absolute encoder, single turn - with brake - degree of protection: standard

**Ordering – Product options**

	<p><b>Configurable product</b></p>	<p><b>This product and all its options can be ordered using the configurator.</b></p>	<p>The configurator can be found under Products on the DVD or                  → <a href="http://www.festo.com/catalogue/...">www.festo.com/catalogue/...</a></p>	<p>Enter the type code in the search field.</p>
---	------------------------------------	---	---	---

## Accessories – Ordering data

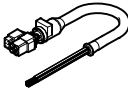
## Motor cable

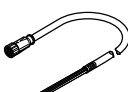
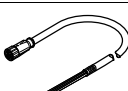
	Cable length [m]	Part no.	Type
<b>for EMMS-AS-40/55 with encoder</b>			
	5.0	550306	NEBM-T1G7-E-5-N-LE7
	10.0	550307	NEBM-T1G7-E-10-N-LE7
	15.0	550308	NEBM-T1G7-E-15-N-LE7
	X length <sup>1)</sup>	550309	NEBM-T1G7-E- -N-LE7
<b>for EMMS-AS-70 and EMMS-AS/40/55 with resolver</b>			
	5.0	1732657	NEBM-M23G8-E-5-N-LE8
	10.0	1732658	NEBM-M23G8-E-10-N-LE8
	15.0	1732659	NEBM-M23G8-E-15-N-LE8
	X length <sup>1)</sup>	1732660	NEBM-M23G8-E- -N-LE8
<b>for EMMS-AS-70/100/140</b>			
	5.0	550310	NEBM-M23G6-E-5-N-LE7
	10.0	550311	NEBM-M23G6-E-10-N-LE7
	15.0	550312	NEBM-M23G6-E-15-N-LE7
	X length <sup>1)</sup>	550313	NEBM-M23G6-E- -N-LE7
<b>for EMMS-AS-190</b>			
	5.0	1750241	NEBM-M40G8-E-5-N-LE7
	10.0	1750242	NEBM-M40G8-E-10-N-LE7
	15.0	1750243	NEBM-M40G8-E-15-N-LE7
	X length <sup>1)</sup>	1750244	NEBM-M40G8-E- -N-LE7

1) Max. 25 m. Cable lengths > 25 m possible following technical clarification; up to 100 m on request.  
Available in Q1 m increments.

## Encoder cable

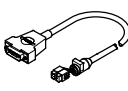
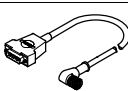
	Cable length [m]	Part no.	Type
<b>for EMMS-AS-40/55</b>			
	5.0	550314	NEBM-T1G8-E-5-N-S1G15
	10.0	550315	NEBM-T1G8-E-10-N-S1G15
	15.0	550316	NEBM-T1G8-E-15-N-S1G15
	X length <sup>1)</sup>	550317	NEBM-T1G8-E- -N-S1G15
<b>for EMMS-AS-70/100/140/190</b>			
	5.0	550318	NEBM-M12W8-E-5-N-S1G15
	10.0	550319	NEBM-M12W8-E-10-N-S1G15
	15.0	550320	NEBM-M12W8-E-15-N-S1G15
	X length <sup>1)</sup>	550321	NEBM-M12W8-E- -N-S1G15

1) Max. 25 m. Cable lengths > 25 m possible following technical clarification; up to 100 m on request.  
Available in Q1 m increments.

## Resolver cable

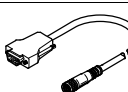
	Cable length [m]	Part no.	Type
<b>for EMMS-AS-40/55/70/100/140/190</b>			
	5.0	1732653	NEBM-M23G12-E-5-N-S1G9
	10.0	1732654	NEBM-M23G12-E-10-N-S1G9
	15.0	1732655	NEBM-M23G12-E-15-N-S1G9
	X length <sup>1)</sup>	1732656	NEBM-M23G12-E- -N-S1G9

1) Max. 25 m. Cable lengths > 25 m possible following technical clarification; up to 100 m on request.  
Available in Q1 m increments.

**Dimensions**

**Flange size 40 – with encoder**

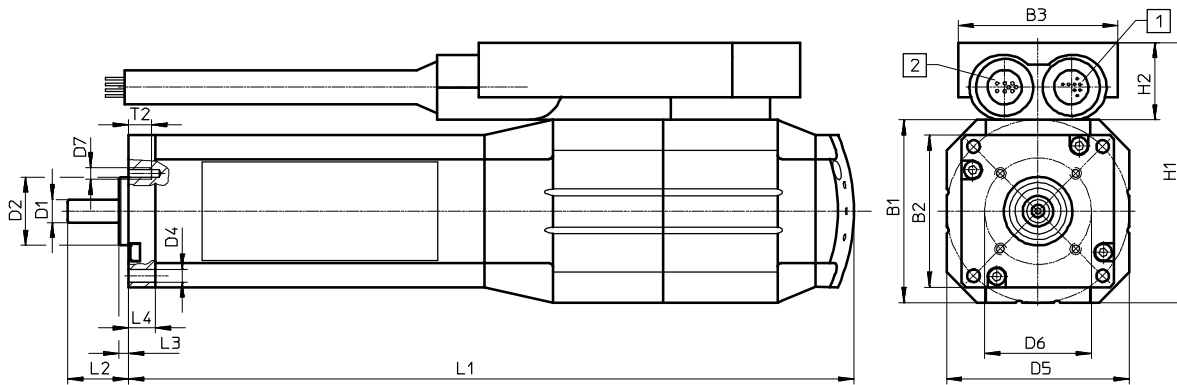

- 1 Encoder cable
- 2 Motor cable

Length	B1	B2	B3	D1 ∅ +0.009/-0.001	D2 ∅ +0.012/-0.006	D4 ∅	D5 ∅	D6 ∅
S	48	40	42	6	18	3.3	48	28
M								

Length	D7	H1	H2	L1	L2	L3 -0.1	L4	T2
S	M3	68.3	20.3	170.5	16	2.5	7	6
M				190.5				

**Flange size 40 – with resolver**

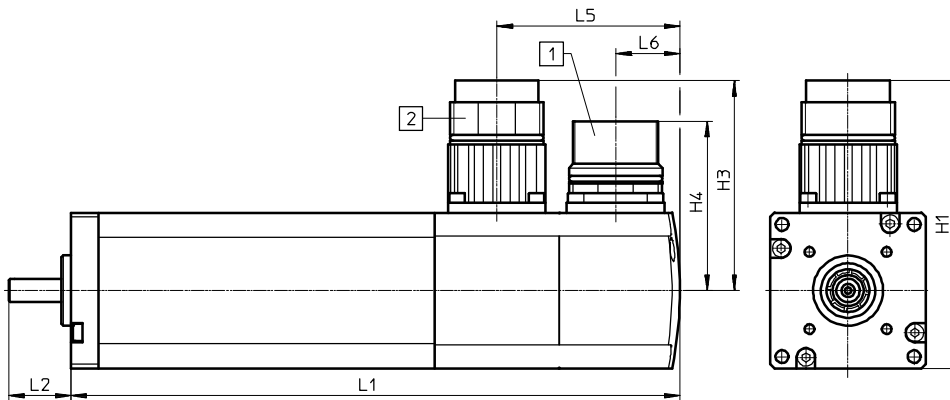

**Note**  
 Dimensions of the shaft and mounting holes → drawing above

- 1 Resolver connection
- 2 Motor connection

Length	H1	H3	H4	L1		L2	L5		L6
					With brake			With brake	
S	74	54	44	134.9	136.4	16	46.5	48	17
M				154.9	156.4				

# Servo motors EMMS-AS

## Dimensions

### Flange size 55 – with encoder

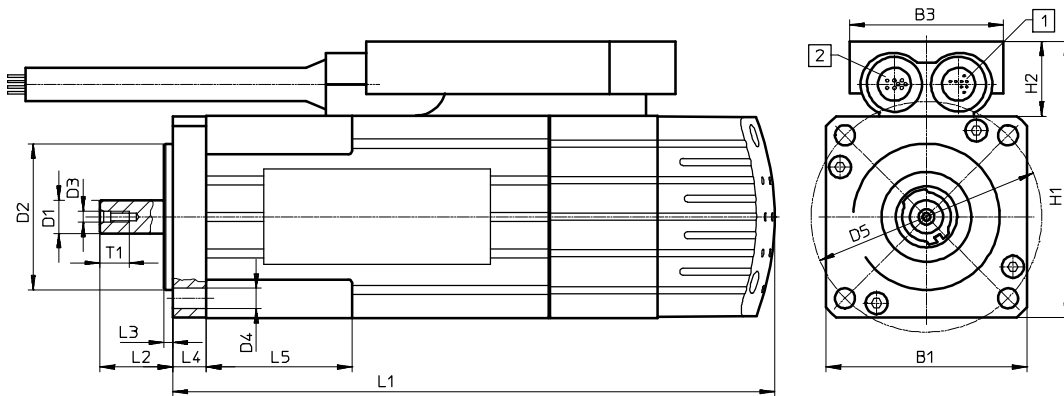

- 1 Encoder cable
- 2 Motor cable

Length	B1	B3	D1 ∅ +0.01/-0.001	D2 ∅ +0.11/-0.005	D3	D4 ∅	D5 ∅
S	55	42	9	40	M2.5	5.5	63
M							

Length	H1	H2	L1	L2	L3 ±0.05	L4	L5	T1
S	76	20.5	139.4	20	2.5	9	40	8
M			164.4					

### Flange size 55 – with resolver

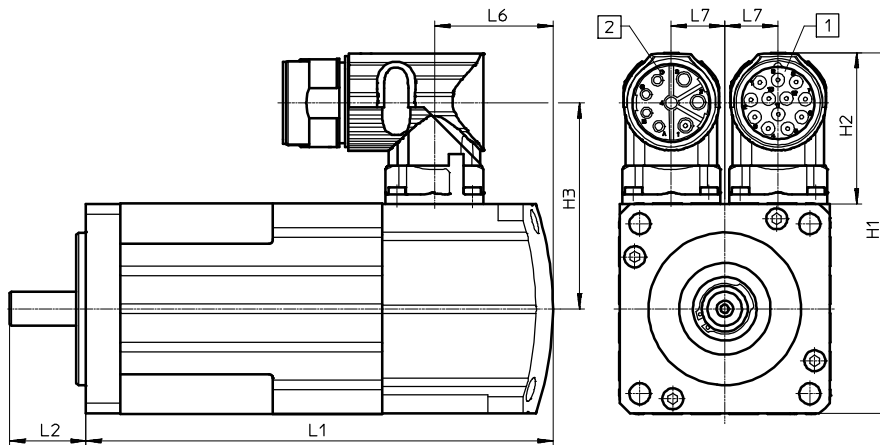

**Note**  
Dimensions of the shaft and mounting holes → drawing above

- 1 Resolver connection
- 2 Motor connection

Length	H1	H2	H3	L1		L2	L6		L7
					With brake			With brake	
S				122.4	139.4	20	31	48	14
M	94.7	39.7	54	147.4	164.4				

**Dimensions**

Flange size 70, 100, 140, 190 – with encoder

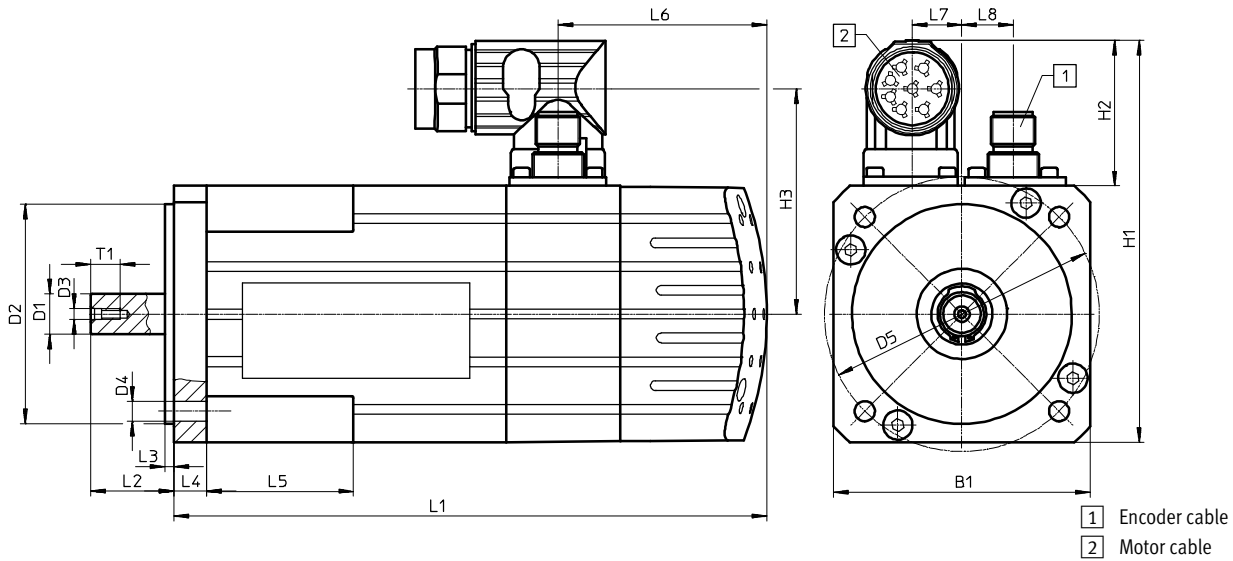

- 1 Encoder cable
- 2 Motor cable

Length	B1	D1 ∅	D2 ∅	D3	D4 ∅	D5 ∅	H1	H2	H3
<b>Flange size 70</b>									
S	70	11+0,012/+0.001	60+0,012/-0.007	M2.5	5.5	75	109.7	39.7	61.5
M									
<b>Flange size 100</b>									
S	100.5	19+0,015/+0.002	95+0,013/-0.009	M4	9.2	115	140	39.7	77
M									
L									
<b>Flange size 140</b>									
S	140.5	24+0,015/-0.002	130+0,018/-0.007	M4	11.3	165	181	39.7	97.7
L									
<b>Flange size 190</b>									
S	190	32+0,018/+0.002	180+0,14/-0.011	M4	13.7	215	251	61	136
M									

Length	L1	L2	L3	L4	L5	L6	L7	L8	T1
<b>Flange size 70</b>									
S	161.8	22.7	2.5-0.1	9	40	57	14	14	8
M	187.3								
<b>Flange size 100</b>									
S	192.3	40	3	9.8	-	58.9	19	19	16
M	243.3								
L	294.3								
<b>Flange size 140</b>									
S	209	50	3.5	12.2	-	58.6	33.5	33.5	16
L	285.5								
<b>Flange size 190</b>									
S	262	60	4-0.1	11	-	81	25	33	16
M	300								

# Servo motors EMMS-AS

## Dimensions

Flange size 70, 100, 140, 190 – with resolver

4

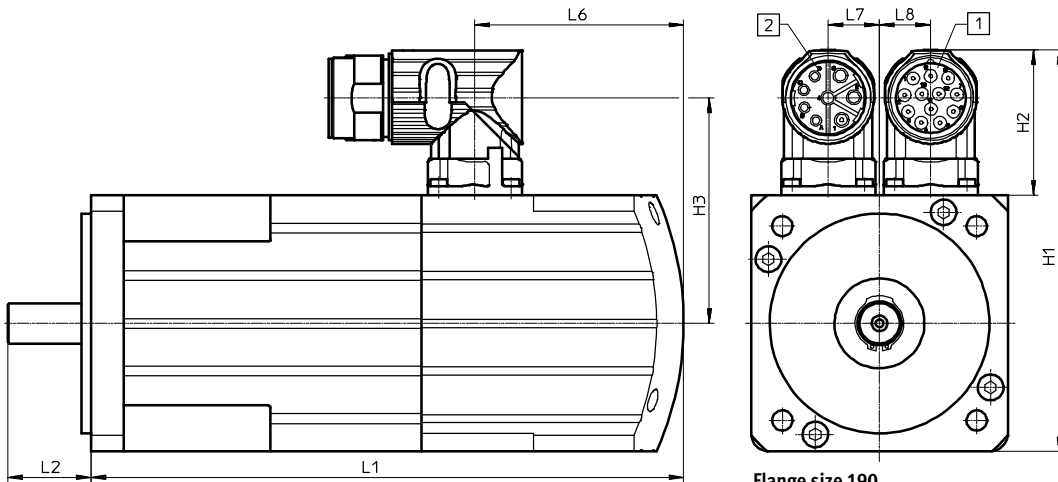

Flange size 190

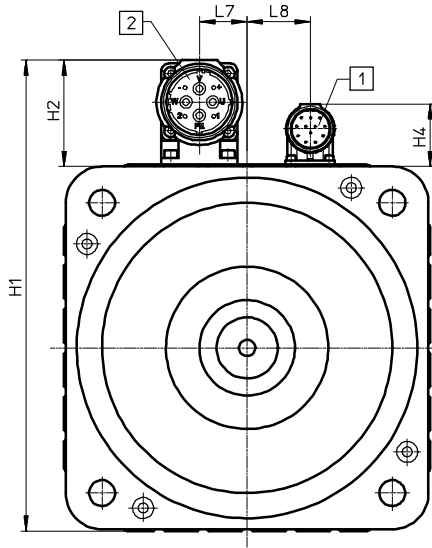

- 1 Resolver connection
- 2 Motor connection

**Note**  
Dimensions of the shaft and mounting holes → 547

Length	H1	H2	H3	H4	L1		L2	L6		L7	L8
						With brake			With brake		
<b>Flange size 70</b>											
S	109.7	39.7	61.5	-	139.8	161.8	22.7	35	57	14	14
M					165.3	187.3					
<b>Flange size 100</b>											
S	140.2	39.7	76.8	-	171.1	192.1	40	37.8	58.9	19	19
M					222.1	243.1					
L					273.1	294.1					
<b>Flange size 140</b>											
S	180.2	39.7	96.8	-	194.6	209	50	44.2	58.6	33.5	33.5
L					271.1	285.5					
<b>Flange size 190</b>											
S	244	54	128.8	33	225	262	60	44	81	25	33
M					263	300					

**Note**  
Only motors without feather key should be used in combination with parallel and axial kits (EAMM-U/EAMM-A).





Overview/Configuration/Ordering

→ [www.festo.com/catalogue/emms-st](http://www.festo.com/catalogue/emms-st)



Additional information/Support/User documentation

→ [www.festo.com/sp/emms-st](http://www.festo.com/sp/emms-st)

Stepper motors

Stepper motors

# EMMS-ST

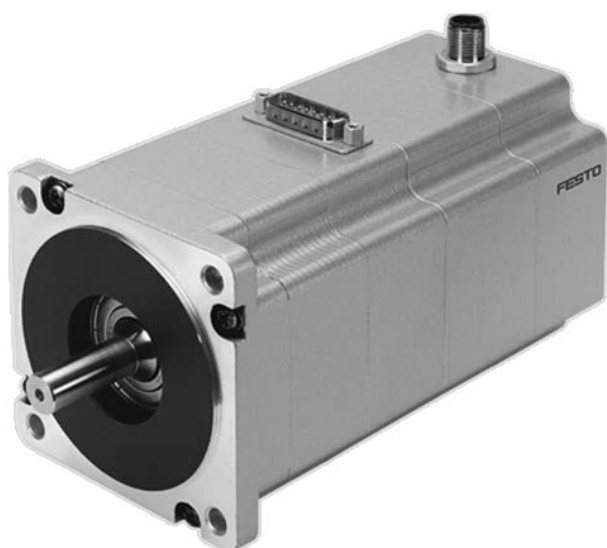

- + 2-phase hybrid technology
- + Step angle 1.8°
- + Standard industrial connection technology
- + Optional: encoder, brake



- Suitable for motor controller CMMS-ST
- Optional encoder with full closed-loop functionality
- Matching gear unit
- Degree of protection IP54
- ★ Quick ordering of basic designs → 554

→ [www.festo.com/catalogue/emms-st](http://www.festo.com/catalogue/emms-st)

### Product range overview

Motor flange size	Nominal voltage [V DC]	Holding torque [Nm]	With encoder	With gear unit	With brake
28	48	0.09	■	■	■
42	48	0.5	■	■	■
57	48	0.8 ... 1.4	■	■	■
87	48	2.5 ... 9.3	■	■	■

**Data sheet**

4

<b>Technical data</b>									Dimensions → 556
Motor flange size		28	42	57-S	57-M	87-S	87-M	87-L	
Nominal voltage	[V DC]	48							
Nominal current	[A]	1.4	1.8	5		9.5			
Holding torque	[Nm]	0.09	0.5	0.8	1.4	2.5	5.9	9.3	
Step angle	[°]	1.8 ±5%							
<b>Brake</b>									
Operating voltage	[V DC]	24 ±10%							
Holding torque	[Nm]	0.2	0.4	0.4	1	2			

<b>Technical data – Encoder</b>		
Encoder, optical		
Operating voltage	[V DC]	5
Pulses/revolution	[1/rev]	500
Zero pulse		Yes
Line driver		RS422 protocol

<b>Operating conditions</b>								
Motor flange size		28	42	57-S	57-M	87-S	87-M	87-L
Ambient temperature	[°C]	-10 ... +50						
Degree of protection: motor shaft		IP54						
Degree of protection: motor housing incl. connection technology		IP65	IP54					
Insulation class		B						

# Stepper motors EMMS-ST

## Data sheet

Torque M as a function of rotational speed n

EMMS-ST-28

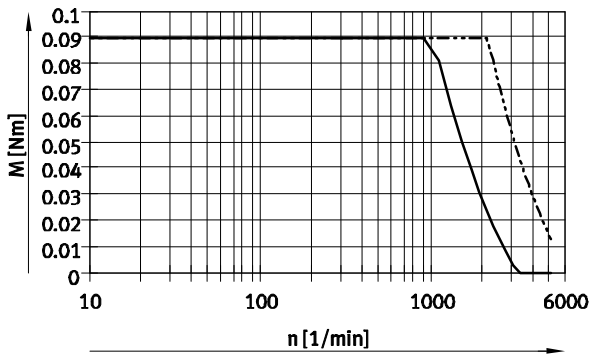

EMMS-ST-42

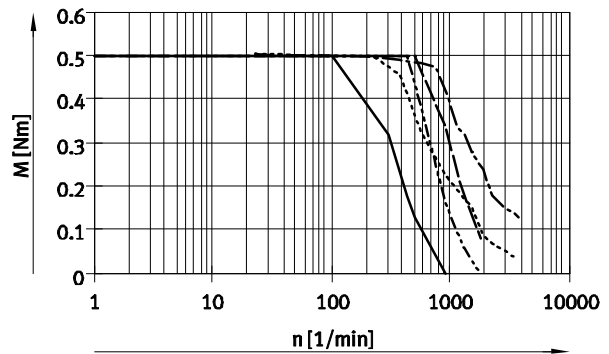

EMMS-ST-57-S

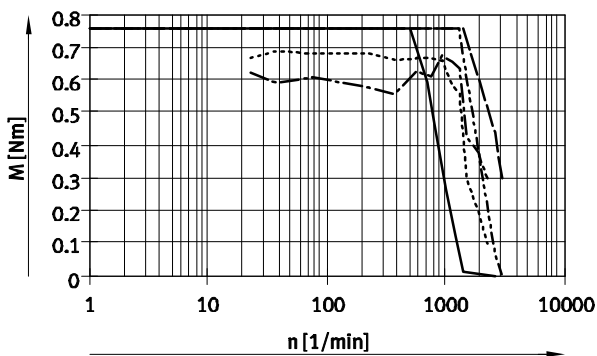

EMMS-ST-57-M

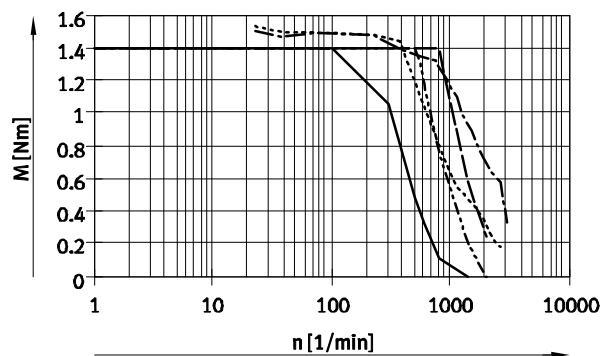

EMMS-ST-87-S

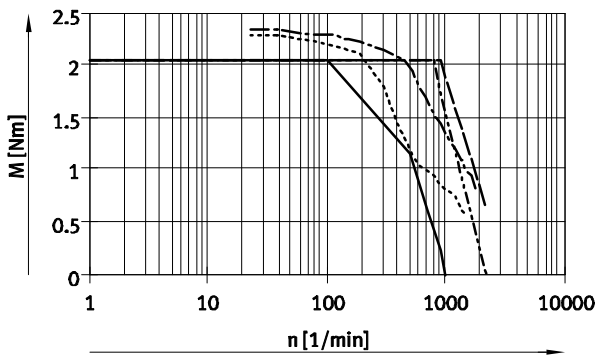

EMMS-ST-87-M

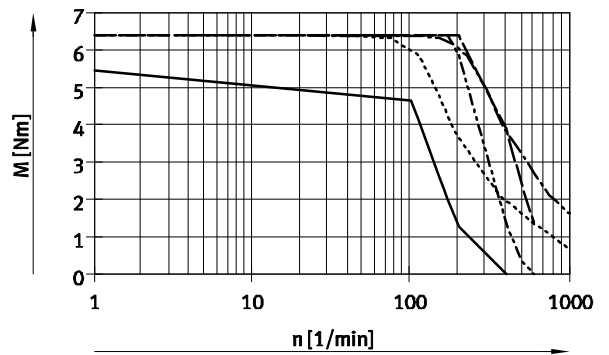

EMMS-ST-87-L

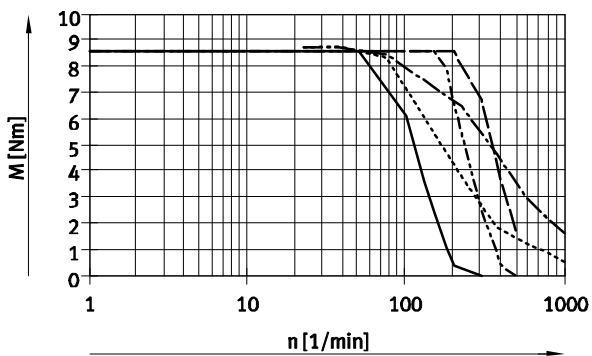

**Note**

The characteristic curves apply in combination with the motor controller CMMS-ST.

The size EMMS-ST-87 is operated with the motor controller CMMS-ST with max. 8 A.

- 24VDC
- - - 48VDC
- · - · 72VDC
- · - · - · 24 V DC ¼ step
- · - · - · - · 48 V DC ¼ step

**Order code**

		EMMS	-	ST	-		-		-	S	-		-		-	
<b>Type</b>																
EMMS	Motor															
<b>Motor technology</b>																
ST	Stepper motor															
<b>Motor flange size</b>																
28	28	1														
42	42	2														
57	57	3														
87	87															
<b>Length</b>																
S	Short															
M	Medium															
L	Long															
<b>Electrical connection</b>																
S	Straight plug															
<b>Measuring unit</b>																
-	Not specified															
E	Encoder															
<b>Brake</b>																
-	Not specified															
B	Brake															
<b>Generation</b>																
G2	2nd generation	4														

4

- 1 Only with length L
- 2 Only with length S
- 3 Only with lengths S and M
- 4 Not with flange size 28

**Order example:**

EMMS-ST-42-S-SEB-G2

Motor EMMS - stepper motor - flange size 42 - length: short - electrical connection: straight plug - measuring unit: encoder - brake - second generation

**Ordering – Product options**

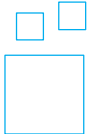
	<p><b>Configurable product</b></p>	<p><b>This product and all its options can be ordered using the configurator.</b></p>	<p>The configurator can be found under Products on the DVD or                  → <a href="http://www.festo.com/catalogue/...">www.festo.com/catalogue/...</a></p>	<p>Enter the type code in the search field.</p>
---	------------------------------------	---	---	---

★ Quick ordering<sup>1)</sup>

Part no.	Type
<b>Flange size 28, length: long</b>	
1451384	EMMS-ST-28-L-S
1430663	EMMS-ST-28-L-SE
1451383	EMMS-ST-28-L-SB
1451382	EMMS-ST-28-L-SEB
<b>Flange size 42, length: short</b>	
1370470	EMMS-ST-42-S-S-G2
1370471	EMMS-ST-42-S-SE-G2
1370472	EMMS-ST-42-S-SB-G2
1370473	EMMS-ST-42-S-SEB-G2

Part no.	Type
<b>Flange size 57, length: short</b>	
1370474	EMMS-ST-57-S-S-G2
1370475	EMMS-ST-57-S-SE-G2
1370476	EMMS-ST-57-S-SB-G2
1370477	EMMS-ST-57-S-SEB-G2
<b>Flange size 57, length: medium</b>	
1370478	EMMS-ST-57-M-S-G2
1370479	EMMS-ST-57-M-SE-G2
1370480	EMMS-ST-57-M-SB-G2
1370481	EMMS-ST-57-M-SEB-G2

Part no.	Type
<b>Flange size 87, length: short</b>	
1370482	EMMS-ST-87-S-S-G2
1370483	EMMS-ST-87-S-SE-G2
1370484	EMMS-ST-87-S-SB-G2
1370485	EMMS-ST-87-S-SEB-G2
<b>Flange size 87, length: medium</b>	
1370486	EMMS-ST-87-M-S-G2
1370487	EMMS-ST-87-M-SE-G2
1370488	EMMS-ST-87-M-SB-G2
1370489	EMMS-ST-87-M-SEB-G2
<b>Flange size 87, length: long</b>	
1370490	EMMS-ST-87-L-S-G2
1370491	EMMS-ST-87-L-SE-G2
1370493	EMMS-ST-87-L-SB-G2
1370494	EMMS-ST-87-L-SEB-G2



1) All products in this table are easy to select and quick to order.

**Accessories – Ordering data**

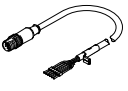
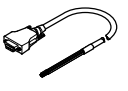
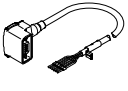
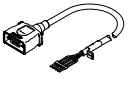
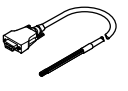
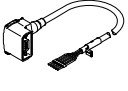
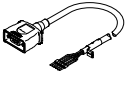
**Motor cable**

	Cable length [m]		Part no.	Type
<b>For EMMS-ST-28 and motor controller CMMO-ST</b>				
<b>Straight plug</b>				
	1.5	★	1449600	NEBM-M12G8-E-1.5-Q5-LE6
	2.5	★	1449601	NEBM-M12G8-E-2.5-Q5-LE6
	5.0	★	1449602	NEBM-M12G8-E-5-Q5-LE6
	7.0	★	1449603	NEBM-M12G8-E-7-Q5-LE6
	10.0	★	1449604	NEBM-M12G8-E-10-Q5-LE6
	X length <sup>1)</sup>		1449605	NEBM-M12G8-E-...-Q5-LE6
<b>For EMMS-ST-42/57 and motor controller CMMS-ST</b>				
<b>Straight plug</b>				
	5.0		550740	NEBM-S1G9-E-5-LE6
	10.0		550741	NEBM-S1G9-E-10-LE6
	15.0		550742	NEBM-S1G9-E-15-LE6
	X length <sup>1)</sup>		550743	NEBM-S1G9-E-...-LE6
<b>and motor controller CMMO-ST</b>				
<b>Angled plug connector</b>				
	1.5	★	1450736	NEBM-S1W9-E-1.5-Q5-LE6
	2.5	★	1450737	NEBM-S1W9-E-2.5-Q5-LE6
	5.0	★	1450738	NEBM-S1W9-E-5-Q5-LE6
	7.0	★	1450739	NEBM-S1W9-E-7-Q5-LE6
	10.0	★	1450740	NEBM-S1W9-E-10-Q5-LE6
	X length <sup>1)</sup>		1450741	NEBM-S1W9-E-...-Q5-LE6
<b>Straight plug</b>				
	1.5	★	1450368	NEBM-S1G9-E-1.5-Q5-LE6
	2.5	★	1450369	NEBM-S1G9-E-2.5-Q5-LE6
	5.0	★	1450370	NEBM-S1G9-E-5-Q5-LE6
	7.0	★	1450371	NEBM-S1G9-E-7-Q5-LE6
	10.0	★	1450372	NEBM-S1G9-E-10-Q5-LE6
	X length <sup>1)</sup>		1450373	NEBM-S1G9-E-...-Q5-LE6
<b>For EMMS-ST-87 and motor controller CMMS-ST</b>				
<b>Straight plug</b>				
	5.0		550744	NEBM-S1G15-E-5-LE6
	10.0		550745	NEBM-S1G15-E-10-LE6
	15.0		550746	NEBM-S1G15-E-15-LE6
	X length <sup>1)</sup>		550747	NEBM-S1G15-E-...-LE6
<b>and motor controller CMMO-ST</b>				
<b>Angled plug connector</b>				
	1.5	★	1450943	NEBM-S1W15-E-1.5-Q7-LE6
	2.5	★	1450944	NEBM-S1W15-E-2.5-Q7-LE6
	5.0	★	1450945	NEBM-S1W15-E-5-Q7-LE6
	7.0	★	1450946	NEBM-S1W15-E-7-Q7-LE6
	10.0	★	1450947	NEBM-S1W15-E-10-Q7-LE6
	X length <sup>1)</sup>		1450948	NEBM-S1W15-E-...-Q7-LE6
<b>Straight plug</b>				
	1.5	★	1450834	NEBM-S1G15-E-1.5-Q7-LE6
	2.5	★	1450835	NEBM-S1G15-E-2.5-Q7-LE6
	5.0	★	1450836	NEBM-S1G15-E-5-Q7-LE6
	7.0	★	1450837	NEBM-S1G15-E-7-Q7-LE6
	10.0	★	1450838	NEBM-S1G15-E-10-Q7-LE6
	X length <sup>1)</sup>		1450839	NEBM-S1G15-E-...-Q7-LE6

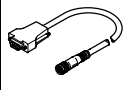
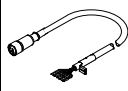
**Encoder cable**

	Cable length [m]		Part no.	Type
<b>For motor controller CMMS-ST</b>				
<b>Straight plug</b>				
	5.0		550748	NEBM-M12G8-E-5-S1G9
	10.0		550749	NEBM-M12G8-E-10-S1G9
	15.0		550750	NEBM-M12G8-E-15-S1G9
	X length <sup>1)</sup>		550751	NEBM-M12G8-E-...-S1G9
<b>For motor controller CMMO-ST</b>				
<b>Straight plug</b>				
	1.5	★	1451586	NEBM-M12G8-E-1.5-LE8
	2.5	★	1451587	NEBM-M12G8-E-2.5-LE8
	5.0	★	1451588	NEBM-M12G8-E-5-LE8
	7.0	★	1451589	NEBM-M12G8-E-7-LE8
	10.0	★	1451590	NEBM-M12G8-E-10-LE8
	X length <sup>1)</sup>		1451591	NEBM-M12G8-E-...-LE8
<b>Angled plug connector</b>				
	1.5	★	1451674	NEBM-M12W8-E-1.5-LE8
	2.5	★	1451675	NEBM-M12W8-E-2.5-LE8
	5.0	★	1451676	NEBM-M12W8-E-5-LE8
	7.0	★	1451677	NEBM-M12W8-E-7-LE8
	10.0	★	1451678	NEBM-M12W8-E-10-LE8
	X length <sup>1)</sup>		1451679	NEBM-M12W8-E-...-LE8

1) Max. 25 m. Cable lengths > 25 m possible following technical consultation; up to 100 m on request. Available in Q1 m increments.

# Stepper motors EMMS-ST

## Dimensions

Size 28

EMMS-ST...-S/SE

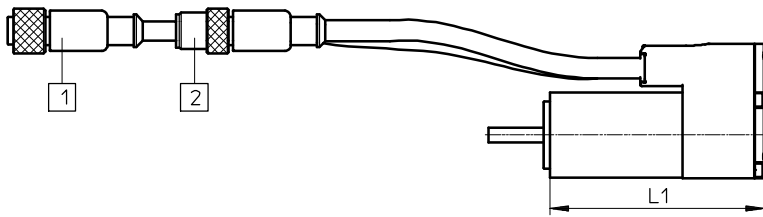

EMMS-ST...-SB/SEB

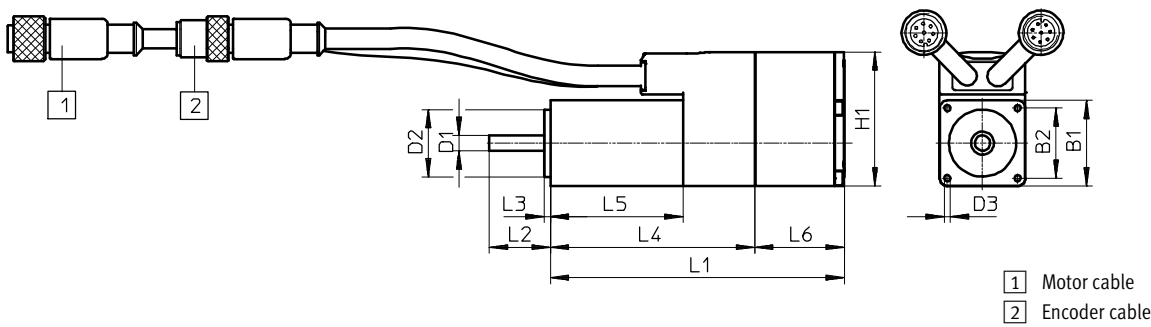

- 1 Motor cable
- 2 Encoder cable

Type	B1	B2	D1 ∅	D2 ∅	D3	H1
	±1	±0.2	-0.013	-0.03		
EMMS-ST-28-L-S	28	23	5	22	M2.5x4.5	44
EMMS-ST-28-L-SE						
EMMS-ST-28-L-SB						
EMMS-ST-28-L-SEB						

Type	L1	L2	L3	L4	L5	L6
		±1		±1	±1	±0.5
EMMS-ST-28-L-S	70±1	20	2	67	43	29
EMMS-ST-28-L-SE						
EMMS-ST-28-L-SB						
EMMS-ST-28-L-SEB						



**Dimensions**

Size 42, 57, 87

EMMS-ST...-S

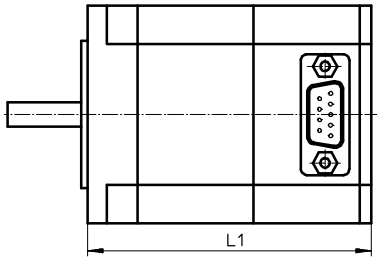

EMMS-ST...-SB

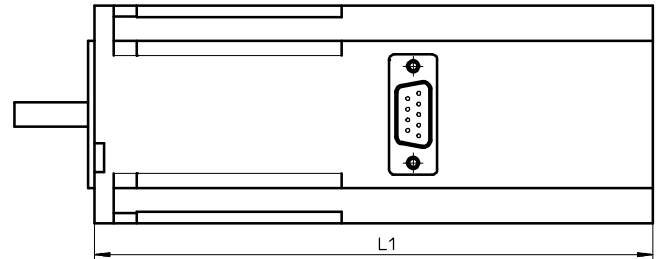

EMMS-ST...-SE/SEB

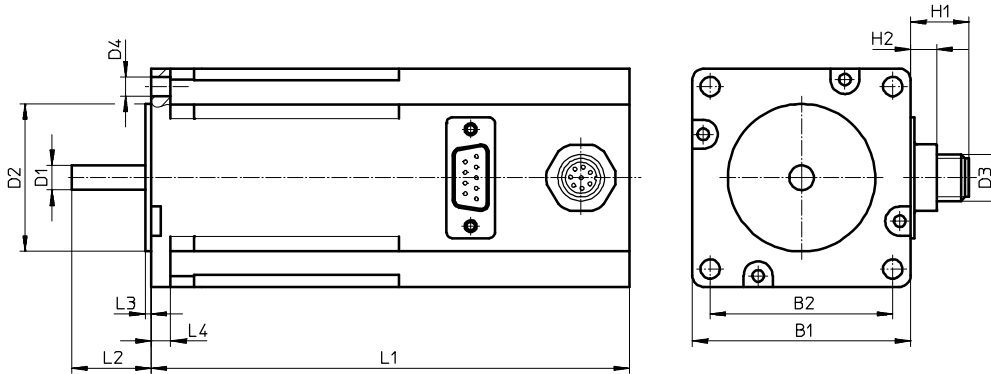

Plug pattern

9-pin Sub-D plug with size 42, 57

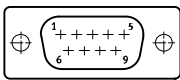

15-pin Sub-D plug with size 87

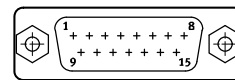

Type	B1	B2 ±0.2	D1 ∅	D2 ∅	D3	D4 ∅	H1	H2	L1	L2	L3	L4
EMMS-ST-42-S-S-G2	42.3	31	5-0012	22-005	-	M3x4.5	-	6.5	66±1	24±1	2	-
EMMS-ST-42-S-SE-G2					M12		13		94±1,2			
EMMS-ST-42-S-SB-G2					-		-		114±1,3			
EMMS-ST-42-S-SEB-G2					M12		13		127±1,3			
EMMS-ST-57-S-S-G2	56.4	47.14	6.35-0013	38.1±0,025	-	5	-	6.5	73.5±0,8	20.6±0,5	1.6	5
EMMS-ST-57-S-SE-G2					M12		13		102.5±1,1			
EMMS-ST-57-S-SB-G2					-		-		123.5±1,1			
EMMS-ST-57-S-SEB-G2					M12		13		138±1,1			
EMMS-ST-57-M-S-G2					-		-		95±0,8			
EMMS-ST-57-M-SE-G2					M12		13		124±1,1			
EMMS-ST-57-M-SB-G2	-	-	145±1,1									
EMMS-ST-57-M-SEB-G2	M12	13	159.5±1,1									
EMMS-ST-87-S-S-G2	85.85	69.5	11-0013	73-0046	-	6.6	-	6.5	82.6±1	27±1	2	8.38
EMMS-ST-87-S-SE-G2					M12		13		112.6±1,3			
EMMS-ST-87-S-SB-G2					-		-		132.6±1,3			
EMMS-ST-87-S-SEB-G2					M12		13		152.6±1,3			
EMMS-ST-87-M-S-G2					-		-		114.9±1			
EMMS-ST-87-M-SE-G2					M12		13		144.9±1,3			
EMMS-ST-87-M-SB-G2					-		-		164.9±1,3			
EMMS-ST-87-M-SEB-G2					M12		13		184.9±1,3			
EMMS-ST-87-L-S-G2					-		-		144.9±1			
EMMS-ST-87-L-SE-G2					M12		13		174.9±1,3			
EMMS-ST-87-L-SB-G2					-		-		194.9±1,3			
EMMS-ST-87-L-SEB-G2					M12		13		214.9±1,3			



Overview/Configuration/Order

→ [www.festo.com/catalogue/cmmp-as](http://www.festo.com/catalogue/cmmp-as)

Additional information/Support/User documentation

→ [www.festo.com/sp/cmmp-as](http://www.festo.com/sp/cmmp-as)

Controllers

Controllers for servo motors

Motor controllers for servo motors

# CMMP-AS

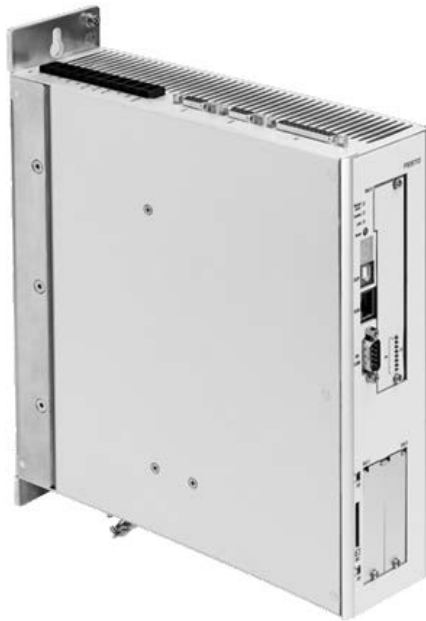

- + Flying saw
- + For cam disk controllers and highly dynamic movements
- + Standardised interfaces allow seamless integration in mechatronic multi-axis modular systems
- + Reliable and convenient commissioning, programming and parameterisation via software tools
- + Optionally with 3 slots for switch or safety module, for extension module



- Closed-loop operation with speed, position, current and torque control
- Optional operation of linear motors
- Suitable for motor EMMS-AS
- Easy configuration with free FCT software
- ★ Quick ordering of basic designs → 563

→ [www.festo.com/catalogue/cmmp-as](http://www.festo.com/catalogue/cmmp-as)

## Product range overview

Type	Nominal voltage Load [V AC]	Nominal voltage Logic [V DC]	Interfaces							
			I/O interface	CANOpen	Modbus/TCP	PROFIBUS DP	DeviceNet	EtherCAT	EtherNet/IP	PROFINET RT
CMMP-AS-C2-...	100 ... 230	24	■	■	■	■	■	■	■	■
CMMP-AS-C5-3A-...	100 ... 230	24	■	■	■	■	■	■	■	■
CMMP-AS-C5-11A-...	3x 230 ... 480	24	■	■	■	■	■	■	■	■
CMMP-AS-C10-...	3x 230 ... 480	24	■	■	■	■	■	■	■	■
CMMP-AS-C20-...	3x 230 ... 480	24	■	■	–	■	■	■	–	–

## Features

### Compactness

- Small dimensions
- Full integration of all components for the controller and power section, including RS232- and CANopen interface
- Integrated brake chopper
- Integrated EMC filters
- Automatic actuation for a holding brake
- Complies with the current CE and EN standards without additional external measures (motor cable length of up to 25 m)

### Fieldbus interfaces

Integrated:

**CANopen**

Optional:

**PROFIBUS**

**DeviceNet**

Optional:

**EtherCAT**

**PROFINET**

**EtherNet/IP**

### Motion control

- Evaluation of digital absolute encoder (EnDat/HIPERFACE) in single-turn or multi-turn versions
- Can be operated as a torque, speed or position controller
- Integrated position controller
- Time-optimised (trapezoidal) or jerk-free (S-shaped) positioning
- Absolute and relative movements
- Point-to-point positioning with and without motion path smoothing
- Position synchronisation
- Electronic gear unit
- 255 position sets
- Wide range of homing methods

### Input / Output

- Freely programmable I/Os
- High-resolution 16-bit analogue input
- Jog/Teach mode
- Simple connection to a higher-order controller via I/O or fieldbus
- Synchronous operation
- Master/Slave mode
- Additional I/Os with the plug-in card CAMC-D-8E8A → 564

### Integrated sequence control

- Automatic sequence of position sets without a higher-order controller
- Linear and cyclical position sequences
- Adjustable delay times
- Branches and wait positions
- Overlapping restart possible during the movement

## Features

### Integrated safety functions

- The motor controller CMMP-AS supports the "Safe Torque Off (STO)" safety function and, by providing a reliable time delay, also supports "Safe Stop 1 (SS1)" with protection against unexpected start-up in accordance with EN 61800-5-2
- Two-channel disconnection of the output stage
- Less external wiring
- Shorter response times in the event of an error
- Faster restart, intermediate circuit remains charged

### Interpolating multi-axis movement

- With a suitable controller, the CMMP-AS can perform path movements with interpolation via CANopen or EtherCat. The controller specifies setpoint position values in a fixed time slot pattern

to this end. In between, the servo position controller independently interpolates the data values between two data points.

4

### Travel program

- Linking of any number of position sets into a travel program
- Step criteria for the travel program possible via digital inputs, for example  
MC – motion complete  
I/O – digital inputs

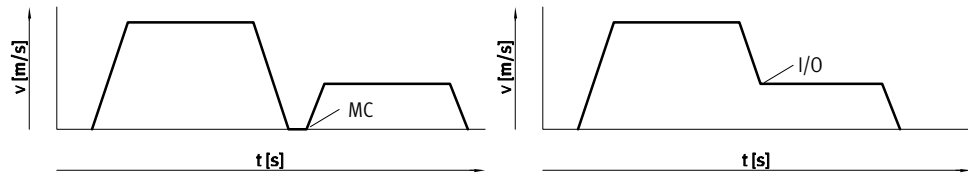

### Library for EPLAN



EPLAN macros for fast and reliable planning of electrical projects in combination with motor controllers, motors and cables.

This enables a high level of planning reliability, standardisation of documentation, no need to create symbols, graphics and master data.

### Cam disc functionality

The "electronic cam disc" application type creates optimised motion profiles that generate less vibration and acceleration force at the machine. In addition, the motion of the motor is always synchronous in position with a master axis, which enables easy definition of overlapping, time-optimised motion sequences.

To be able to use the cam disc function, you will need the Festo Configuration Tool (FCT) and also the curve editor → online: cmmf.

Key features:

- High flexibility of the system. The mechanics do not need to be modified if the requirements for the curve shapes change.
- User-friendly motion plan editor. All limits for position, speed and acceleration are immediately displayed in the editor.
- Up to 16 cam discs with a total of up to 2048 data points can be managed. The data points can be randomly distributed along the cam discs.
- There are four digital trip cams coupled with each cam disc.
- Each cam disc can be offset by a certain amount from the master axis.

## System overview

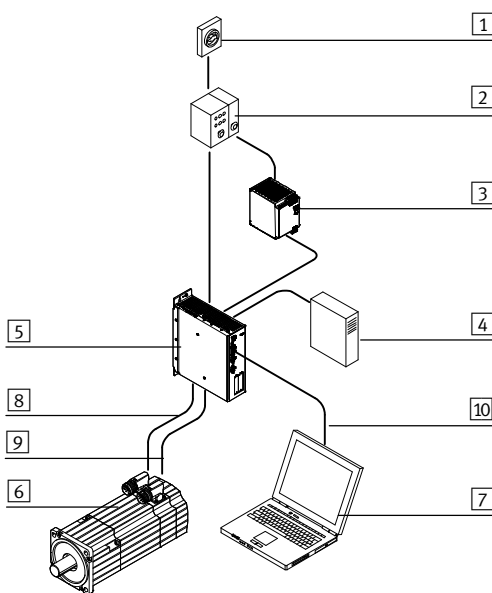

- 1 Main switch
- 2 Circuit breaker
- 3 24 V DC power supply unit
- 4 External braking resistor (optional)
- 5 Motor controller CMMP-AS
- 6 Motor EMMS-AS
- 7 PC
- 8 Encoder cable
- 9 Motor cable
- 10 Programming cable

## Data sheet

## Fieldbus interfaces

CANopen

PROFIBUS

DeviceNet

EtherCAT

PROFINET

EtherNet/IP



4

Technical data		Download CAD data → <a href="http://www.festo.com">www.festo.com</a>				
CMMP-AS-		C2-3A-...	C5-3A-...	C5-11A-P3-...	C10-11A-P3-...	C20-11A-P3
Parameterisation interface		USB, Ethernet				RS232
Active PFC		Yes	-			
Encoder interface input		Resolver				
		Incremental encoder with analogue or digital tracking signals				
		Absolute encoder with EnDat V2.1 serial/V2.2				
		Absolute encoder with HIPERFACE				
		Additional input for synchronous/cam disc operation				
Encoder interface output		Actual value feedback via encoder signals in speed control mode				
		Setpoint specification for downstream slave drive				
		Resolution up to 16384 ppr				
Braking resistor, integrated	[Ω]	60		68		47
Pulse power of braking resistor	[kVA]	2.8		8.5		12
Number of analogue outputs		2				
Operating range of analogue outputs	[V]	±10				
Resolution of analogue outputs	[bit]	9				
Number of analogue inputs		3				
Operating range of analogue inputs	[V]	±10				
Mains filter		Integrated				
Safety function		Optional → 564				Integrated

Electrical data						
CMMP-AS-		C2-3A-...	C5-3A-...	C5-11A-P3-...	C10-11A-P3-...	C20-11A-P3
Load supply						
Input voltage range	[V AC]	100 ... 230 ±10%		3x 230 ... 480 ±10%		
Max. nominal input current	[A]	3	6	5.5	11	20
Rated output	[VA]	500	1000	3000	6000	12000
Peak power	[VA]	1000	2000	6000	12000	25000
Mains frequency	[Hz]	50 ... 60				
Logic supply						
Nominal voltage	[V DC]	24 ±20%				
Nominal current	[A]	0.55/2.05 <sup>1)</sup>	0.65/2.15 <sup>1)</sup>	1/3.5 <sup>1)</sup>		

1) Max. current with brake and I/Os.

Operating conditions						
CMMP-AS-		C2-3A-...	C5-3A-...	C5-11A-P3-...	C10-11A-P3-...	C20-11A-P3
Ambient temperature	[°C]	0 ... +40				
Degree of protection		IP20				
Safety function		Safe Torque Off (STO)				
Performance Level (PL)		Category 4, Performance Level e				Category 3, Performance Level d
Safety Integrity Level (SIL)		SIL 3				SIL 2
CE marking (see declaration of conformity)		To EU EMC Directive				
		To EC Machinery Directive				

# Motor controllers CMMP-AS, for servo motors

## Data sheet

Technical data – Fieldbus interface										
Interfaces	I/O	Additional I/O <sup>1)</sup>	CANOpen	Modbus/TCP	PROFIBUS DP	DeviceNet	EtherCAT	EtherNet/IP	PROFINET RT	
Number of digital logic outputs	5	8	5							
Characteristics of digital logic outputs	Freely configurable									
Number of digital logic inputs	10	8	10							
Characteristics of logic inputs	Freely configurable									
Process coupling	16 (127 position sets <sup>2)</sup> )	255 position sets	250 position sets							
Communication profile	–	–	DS301, FHPP+	FHPP+	DP-V0 / FHPP+	FHPP+	DS301, FHPP+	FHPP+	FHPP+	
			DS301, DSP402				CoE: DS301, DSP402			
Max. fieldbus transmission rate [Mbps]	–	–	1	100	12	0.5	100	100	100	
Interface										
CMMP-AS-...-M0	Integrated	■	–	■	■	–	–	–	–	–
CMMP-AS-...-M3	Integrated	■	–	■	■	–	–	–	–	–
	Optional <sup>3)</sup>	–	■	–	–	■	■	■	■	■
CMMP-AS-C20-11A-P3	Integrated	■	–	■	–	–	–	–	–	–
	Optional <sup>3)</sup>	–	–	–	–	■	■	■	–	–

1) With additional I/O plug-in card CAMC-D8E8A → 564.

2) Can be expanded with configurable logic inputs up to max. 127 position sets

3) Plug-in cards can be ordered separately → 564

## Order code

		CMMP		AS							
<b>Type</b>											
CMMP	Motor controller, premium										
<b>Motor technology</b>											
AS	AC synchronous										
<b>Nominal current</b>											
C2	2.5 A										
C5	5 A										
C10	10 A										
C20	20 A										
<b>Input voltage</b>											
3 A	100 ... 230 V AC	[1]									
11 A	3x 230 ... 480 V AC	[2]									
<b>Number of phases</b>											
–	1-phase	[3]									
P3	3-phase	[4]									
<b>Number of slots</b>											
M0	No slot	[5]									
–	With 2 slots	[6]									

[1] Not with nominal current C10, C20.

[2] Not with nominal current C2.

[3] Not with input voltage 11 A.

[4] Not with input voltage 3 A.

[5] Only with nominal current C2, C5, C10.

[6] Only with nominal current C20.

### Order example:

CMMP-AS-C2-3A-M0

Motor controller CMMP - AC synchronous - nominal current 2.5 A - input voltage 230 V - single-phase - no slot

## Ordering – Product options

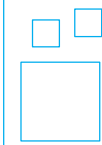

Configurable product

This product and all its options can be ordered using the configurator.

The configurator can be found under Products on the DVD or

Enter the type code in the search field.

→ [www.festo.com/catalogue/...](http://www.festo.com/catalogue/...)

★ Quick ordering<sup>1)</sup>

	Description	Part no.	Type
CMMP-AS-...-M3 – With 3 slots			
	A plug-in card in slot <b>7</b> is mandatory for operation. Possible plug-in cards: <ul style="list-style-type: none"> <li>• CAMC-DS-M1 → 564</li> <li>• CAMC-G-S1 → 564</li> <li>• CAMC-G-S3 →</li> </ul> The plug assortment NEKM (→ 563) is included in the scope of delivery of the motor controller.	★ 1501325	CMMP-AS-C2-3A-M3
		★ 1501326	CMMP-AS-C5-3A-M3
		★ 1501327	CMMP-AS-C5-11A-P3-M3
		★ 1501328	CMMP-AS-C10-11A-P3-M3

1) All products in this table are easy to select and quick to order.

## Accessories – Ordering data

	Part no.	Type		Part no.	Type	
<b>Cable and plug</b>			<b>Cable and plug</b>			
Control cable, for I/O interface to any controller			Assortment of plugs			
	552254	NEBC-S1G25-K-2.5N-LE26 <sup>1</sup>		For CMMP-AS-C2/-C5-3A-M0, CMMP-AS-C2/-C5-3A-M3		
	★ 8001373	NEBC-S1G25-K-3.2N-LE25 <sup>2</sup>		1659228	NEKM-C-7 <sup>3</sup>	
	Programming cable			For CMMP-AS-C5/-C10-11A-P3-M0, For CMMP-AS-C5/-C10-11A-P3-M3		
	1501332	NEBC-U1G-K-1.8-N-U2G		552256	NEKM-C-3 <sup>3</sup>	
	For CMMP-AS-C20-11A-P3			For CMMP-AS-C20-11A-P3		
	160786	PS1-ZK11-NULLMODEM-1,5M		1425453	NEKM-C-6 <sup>4</sup>	
Encoder plug				For interface CAMC-D-8E8A		
	564264	NECC-A-S-S1G9-C2M		569959	NEKM-C-5 <sup>5</sup>	
	Plug			For safety module CAMC-G-S1 Motor controller CMMP-AS-0-M0		
	For PROFIBUS interface			1660640	NEKM-C-8 <sup>6</sup>	
	533780	FBS-SUB-9-WS-PB-K	For safety module CAMC-G-S3			
	For CANopen interface		1660937	NEKM-C-9 <sup>7</sup>		
	533783	FBS-SUB-9-WS-CO-K	<b>Plug-in card</b>			
	For DeviceNet interface			For PROFIBUS interface		
	525635	FBSD-KL-2X5POL		★ 547450	CAMC-PB	
				For DeviceNet interface		
				★ 547451		CAMC-DN
				For EtherCat interface		
				★ 567856		CAMC-EC
				For EtherNet/IP interface		
			★ 1911917		CAMC-F-EP	
			For PROFINET RT interface			
			★ 1911916		CAMC-F-PN	

- 1) Recommended for analogue signals since the cable is shielded
- 2) Cannot be used if the incremental encoder interface (input) is in use
- 3) Plugs are included in the scope of delivery of the motor controller CMMP-AS-...-M0, CMMP-AS-...-M3.
- 4) Plugs are included in the scope of delivery of the motor controller CMMP-AS-C20-11A-P3.
- 5) Plugs are included in the scope of delivery of the plug-in card CAMC-D-8E8A  
Plug is included in the scope of delivery of the motor controller CMMP-AS-...-M0.
- 6) Plug is included in the scope of delivery of the plug-in card CAMC-G-S1.
- 7) Plug is included in the scope of delivery of the plug-in card CAMC-G-S3.

## Accessories – Ordering data

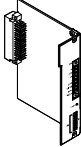
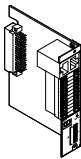
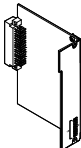
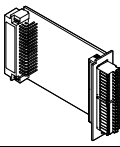
	Part no.	Type
<b>Plug-in card<sup>1)</sup></b>		
Safety module		
	★ 1501330	CAMC-G-S1
		<ul style="list-style-type: none"> <li>• Safe Torque Off (STO)</li> <li>• Safe Brake Control (SBC)</li> </ul>
	1501331	CAMC-G-S3
		<ul style="list-style-type: none"> <li>• Safe Torque Off (STO)</li> <li>• Safe Brake Control (SBC)</li> <li>• Safe Stop 1 (SS1)</li> <li>• Safe Operating Stop (SOS)</li> <li>• Safe Stop 2 (SS2)</li> <li>• Safely Limited Speed (SLS)</li> <li>• Safe speed range (SSR)</li> <li>• Safe speed monitor (SSM)</li> </ul>
Switch module		
	★ 1501329	CAMC-DS-M1
Interface, for extending the digital I/Os <sup>2)</sup>		
	567855	CAMC-D-8E8A

1) The plugs are included in the scope of delivery.  
 2) 8 digital input/outputs.

**Note**  
 Operation of the motor controller CMMP-AS...-M3 absolutely requires that a plug-in card (CAMC-G-S1, CAMC-G-S3 or CAMC-DS-M1) be inserted in slot 1.

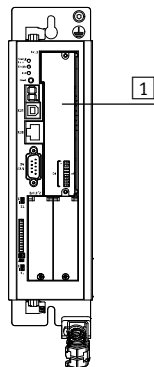

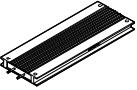
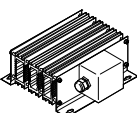
	Part no.	Type
<b>Braking resistor</b>		
	For CMMP-AS-C2-3A, CMMP-AS-C5-3A	
	2882342	CACR-LE2-50-W500 <sup>3)</sup>
	1336611	CACR-LE2-72-W500
	For CMMP-AS-C5-11A-P3, CMMP-AS-C10-11A-P3	
	1336617	CACR-KL2-67-W1800
	2882343	CACR-KL2-40-W2000 <sup>3)</sup>
	For CMMP-AS-C20-11A-P3	
	1336619	CACR-KL2-33-W2400

3) Recommended braking resistor.

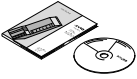
	Type
<b>Documentation and software</b>	
	Ordering data → online: ccmp





Overview/Configuration/Order

→ [www.festo.com/catalogue/cmmo-st](http://www.festo.com/catalogue/cmmo-st)



Additional information/Support/User documentation

→ [www.festo.com/sp/cmmo-st](http://www.festo.com/sp/cmmo-st)

Controllers

Controllers for stepper motors

Motor controllers for stepper motors

# CMMO-ST



- + As open-loop and closed-loop position controller
- + Separate load and logic supply
- + Supports the Safe Torque Off (STO) safety function
- + Easy actuation via I/O interface
- + Monitoring of freely definable position zones
- + Backup file enables seamless device replacement

# Motor controllers CMMO-ST, for stepper motors

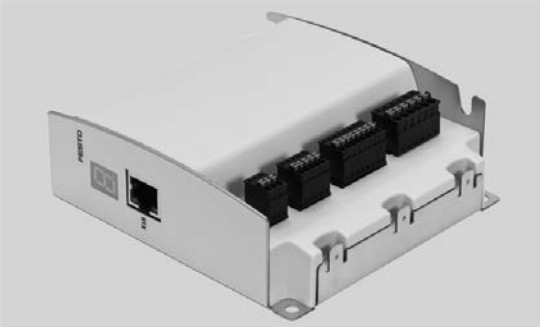

- Open-loop and closed-loop position controller
- Closed-loop encoder option, therefore no step losses
- Monitoring of freely definable position zones
- Simple activation with digital I/O interface or IO-Link
- Easy parameterisation with FCT configuration package or Ethernet interface with integrated web server
- ★ Quick ordering of basic designs → 567

→ [www.festo.com/catalogue/cmmo-st](http://www.festo.com/catalogue/cmmo-st)

## Product range overview

Type	Nominal voltage [V DC]	Nominal current [A]	Interfaces	
			I/O interface -DIOP/-DION	IO-Link -LKP
CMMO-ST	24 ±15%	6	■	■

## Technical data

Technical data		Download CAD data → <a href="http://www.festo.com">www.festo.com</a>	
CMMO-ST-...	-DIOP/-DION	-LKP	
Operating mode			
Open-loop operation	Sinusoidal current form		
Closed-loop operation	Controlled sinusoidal current, cascade controller for speed and position		
Rotary position encoder	Encoder		
Encoder interface input	RS422		
Parameterisation interface	Ethernet		
EtherCat, supported protocols	TCP/IP	TCP/IP, Modbus TCP	
Protocol	–	IO-Link	
		I-Port	
		Modbus TCP	
Position sets	32	64	
Communication profile	–	FHPP	
Number of digital logic inputs	11	1	
Number of digital logic outputs	11	3	

Electrical data			
CMMO-ST-...	-DIOP	-DION	-LKP
General information			
Max. DC link voltage	[V DC]	28	31
Nominal output current	[A]	5.7	
Load voltage			
Nominal voltage	[V DC]	24 ±15%	
Nominal current	[A]	6	
Peak current	[A]	8	
Logic supply			
Nominal voltage	[V DC]	24 ±15%	
Nominal current	[A]	0.3	
Max. current per output	[mA]	100	
Switching logic, input/output	PNP	NPN	PNP

## Data sheet

Operating conditions		
Ambient temperature	[°C]	0 ... +50
Degree of protection		IP40
Safety function		Safe Torque Off (STO)
Performance Level (PL)		Category 3, Performance Level e
Safety Integrity Level (SIL)		SIL 3/SIL CL 3
Certificate issuing authority		TÜV 01/205/5252.01/15
CE marking (see declaration of conformity)		In accordance with EU EMC Directive
		In accordance with EU Machinery Directive

## Ordering – Product options

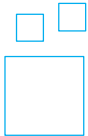

**Configurable product**

**This product and all its options can be ordered using the configurator.**

The configurator can be found under Products on the DVD or  
[www.festo.com/catalogue/...](http://www.festo.com/catalogue/...)

Enter the type code in the search field.

## ★ Quick ordering

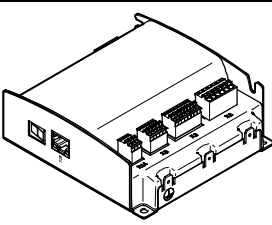
	Description	Part no.	Type
	With I/O interface		
	Switching input/output PNP	★ 1512316	CMMO-ST-C5-1-DIOP
	Switching input/output NPN	★ 1512317	CMMO-ST-C5-1-DION
	With IO-Link		
	Switching input/output PNP	1512320	CMMO-ST-C5-1-LKP

## Accessories – Ordering data

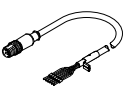
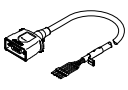
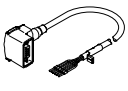
	Cable length [m] <sup>1)</sup>	Part no.	Type
<b>Motor cable for EPCO-16; ERMO-12/-16; EMMS-ST-28</b>			
<b>Straight plug</b>			
	1.5	★ 1449600	NEBM-M12G8-E-1.5-Q5-LE6
	2.5	★ 1449601	NEBM-M12G8-E-2.5-Q5-LE6
	5.0	★ 1449602	NEBM-M12G8-E-5-Q5-LE6
	7.0	★ 1449603	NEBM-M12G8-E-7-Q5-LE6
	10.0	★ 1449604	NEBM-M12G8-E-10-Q5-LE6
<b>for EPCO-25/-40; ELGR-35; ERMO-25/-32; EMMS-ST-42/-57</b>			
<b>Straight plug</b>			
	1.5	★ 1450368	NEBM-S1G9-E-1.5-Q5-LE6
	2.5	★ 1450369	NEBM-S1G9-E-2.5-Q5-LE6
	5.0	★ 1450370	NEBM-S1G9-E-5-Q5-LE6
	7.0	★ 1450371	NEBM-S1G9-E-7-Q5-LE6
	10.0	★ 1450372	NEBM-S1G9-E-10-Q5-LE6
<b>Angled plug</b>			
	1.5	★ 1450736	NEBM-S1W9-E-1.5-Q5-LE6
	2.5	★ 1450737	NEBM-S1W9-E-2.5-Q5-LE6
	5.0	★ 1450738	NEBM-S1W9-E-5-Q5-LE6
	7.0	★ 1450739	NEBM-S1W9-E-7-Q5-LE6
	10.0	★ 1450740	NEBM-S1W9-E-10-Q5-LE6

1) Other cable lengths on request.

## Accessories – Ordering data

	Cable length [m] <sup>1)</sup>	Part no.	Type
<b>Encoder cable</b> for EPCO-16/-25/-40; ELGR-35/-45/-55; ERMO-12/-16/-25/-32; EMMS-ST-28/-42/-57/-87			
	<b>Straight plug</b>		
	1.5	★	1451586 NEBM-M12G8-E-1.5-LE8
	2.5	★	1451587 NEBM-M12G8-E-2.5-LE8
	5.0	★	1451588 NEBM-M12G8-E-5-LE8
	7.0	★	1451589 NEBM-M12G8-E-7-LE8
	10.0	★	1451590 NEBM-M12G8-E-10-LE8

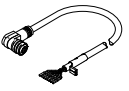
	Cable length [m] <sup>1)</sup>	Part no.	Type
<b>Encoder cable</b> for EPCO-25/-40; ERMO-25/32; EMMS-ST-42/-57/-87			
	<b>Angled plug</b>		
	1.5	★	1451674 NEBM-M12W8-E-1.5-LE8
	2.5	★	1451675 NEBM-M12W8-E-2.5-LE8
	5.0	★	1451676 NEBM-M12W8-E-5-LE8
	7.0	★	1451677 NEBM-M12W8-E-7-LE8
	10.0	★	1451678 NEBM-M12W8-E-10-LE8

1) Other cable lengths on request.

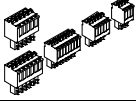
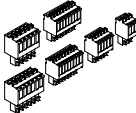
	Description	Part no.	Type
<b>Assortment of plugs</b>			
	Plugs for motor cable, encoder cable, power supply, reference switch, STO safety function.	★ 576005	NEKM-C-10 <sup>2</sup>
	Plugs for motor cable, encoder cable, power supply, reference switch, STO safety function and IO-Link.	2948940	NEKM-C-14 <sup>2</sup>

2) Plugs are included in the scope of delivery of the motor controller.

## Connection options from I/O interface to controller

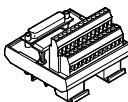
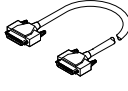
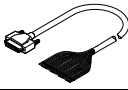
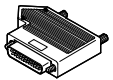
	Description	Cable length [m]	Part no.	Type
<b>Manifold block</b>				
	Ensures simple and clear wiring. The connection to the motor controller is established via the connecting cable NEBC-S1G25-K-....	–	8001371	NEFC-S1G25-C2W25-S7
<b>Connecting cable</b>				
	Connects the motor controller to the connection block.	1.0	8001374	NEBC-S1G25-K-1.0-N-S1G25
		2.0	8001375	NEBC-S1G25-K-2.0-N-S1G25
		5.0	8001376	NEBC-S1G25-K-5.0-N-S1G25
<b>Control cable</b>				
	Is connected to the motor controller. The other end comprises individual flying leads.	3.2	★ 8001373	NEBC-S1G25-K-3.2-N-LE25
<b>Plug</b>				
	25-pin sub-D plug. Each wire can be individually assembled using screw terminals.	–	★ 8001372	NEFC-S1G25-C2W25-S6



Overview/Configuration/Order

→ [www.festo.com/catalogue/cmms-st](http://www.festo.com/catalogue/cmms-st)

Additional information/Support/User documentation

→ [www.festo.com/sp/cmms-st](http://www.festo.com/sp/cmms-st)

Controllers

Controllers for stepper motors

Motor controllers for stepper motors

# CMMS-ST



- + Can be operated as a torque, speed or position controller
- + Position controller, integrated brake chopper
- + I/O coupling
- + Electronic gear unit

# Motor controllers CMMS-ST, for stepper motors



- Open-loop operation, optional closed-loop operation with encoder
- Integrated SD card slot
- Compatible with motor EMMS-ST
- Easy configuration with free FCT software

→ [www.festo.com/catalogue/cmms-st](http://www.festo.com/catalogue/cmms-st)

## Product range overview

Type	Nominal voltage Load [V DC]	Nominal voltage Logic [V DC]	Interfaces			
			I/O interface	CANopen	PROFIBUS	DeviceNet
CMMS-ST-C8-7-G2	24 ... 48	24	■	■	■	■

## Features

### Compactness

- Small dimensions
- Full integration of all components for the controller and power section, including RS232- and CANopen interface
- Integrated brake chopper
- Integrated EMC filters
- Automatic actuation for a holding brake
- Complies with the current CE and EN standards without additional external measures (motor cable length of up to 15 m)

### Fieldbus interfaces

Integrated:



Optional:



### Safety functions

- The motor controller CMMS-ST supports the "Safe Torque Off (STO)" safety function and, by providing a reliable time delay, also supports "Safe Stop 1 (SS1)" with protection against unexpected start-up in accordance with EN 61800-5-2
- Two-channel disconnection of the output stage
- Shorter response times in the event of an error

### Servo mode

- Encoder option (closed loop), in other words no step losses, following errors are corrected

### Motion control

- Can be operated as a torque, speed or position controller
- Integrated position controller
- Time-optimised (trapezoidal) or jerk-free (S-shaped) positioning
- Absolute and relative movements
- Point-to-point positioning with and without motion path smoothing
- Position synchronisation
- Electronic gear unit
- 63 position sets
- 8 positioning profiles
- Wide range of homing methods

### Input / Output

- Freely programmable I/Os
- High-resolution 12-bit analogue input
- Jog/Teach mode
- Simple connection to a higher-order controller via I/O or fieldbus
- Synchronous operation
- Master/slave mode

### Integrated sequence control

- Automatic sequence of position sets without a higher-order controller
- Linear and cyclical position sequences
- Adjustable delay times

### Interpolating multi-axis movement

- With a suitable controller, the CMMS-ST can perform path movements with interpolation via CANopen. To do this, the controller specifies setpoint position values in a fixed time slot pattern. In between, the servo position controller independently interpolates the data values between two data points.

## Features

### Travel program

- Linking of any number of position sets into a travel program
- Step criteria for the travel program possible via digital inputs, for example  
MC – motion complete  
I/O – digital inputs

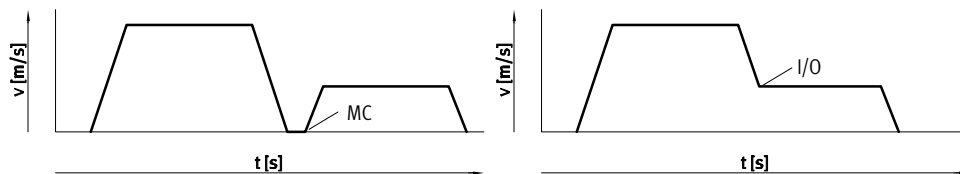

### Library for EPLAN



EPLAN macros for fast and reliable planning of electrical projects in combination with motor controllers, motors and cables.

This enables a high level of planning reliability, standardisation of documentation, no need to create symbols, graphics and master data.

## System overview

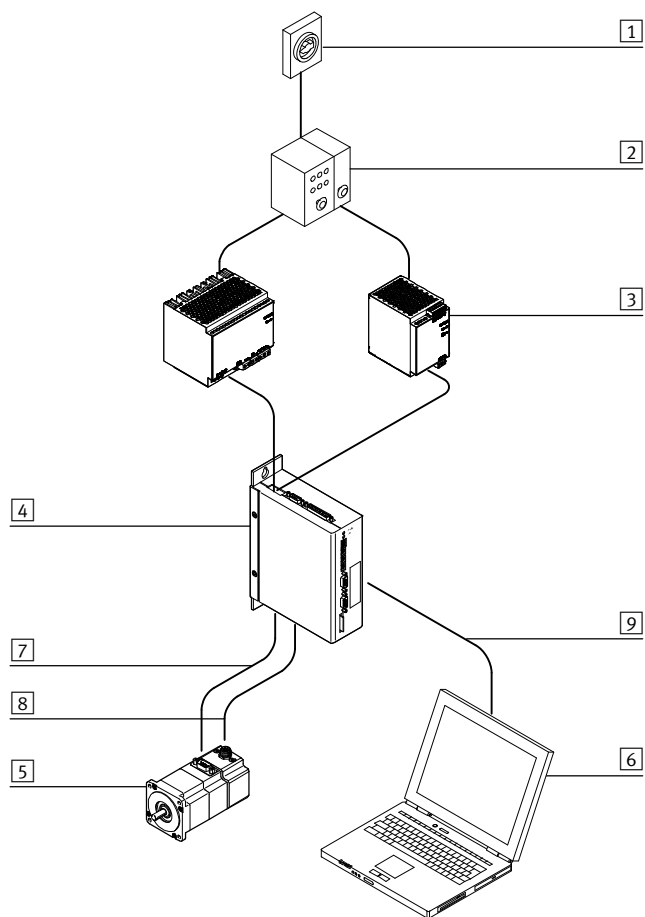

- 1 Main switch
- 2 Circuit breaker
- 3 24 V DC power supply unit
- 4 Motor controller CMMS-ST
- 5 Motor EMMS-ST
- 6 PC
- 7 Motor cable
- 8 Encoder cable
- 9 Programming cable

# Motor controllers CMMS-ST, for stepper motors

FESTO

## Data sheet

### Fieldbus interfaces



4

Technical data		Download CAD data → <a href="http://www.festo.com">www.festo.com</a>
Motor activation		Sinusoidal current injection
Rotor position encoder		Encoder
Parameterisation interface		RS232 (9600 ... 115000 bits/s)
Encoder interface input		As speed/position specification for the slave drive in synchronous mode RS422
Encoder interface output		Setpoint specification for downstream slave drive
Braking resistor, integrated	[Ω]	17
Pulse power of braking resistor	[kVA]	0.5
Impedance of setpoint input	[kΩ]	20
Number of analogue outputs		1
Operating range of analogue outputs	[V]	±10
Number of analogue inputs		1
Operating range of analogue inputs	[V]	±10
Mains filter		Integrated

Electrical data		
Load supply		
Nominal voltage	[V DC]	24 ... 48
Nominal current	[A]	8
Peak current	[A]	12
Logic supply		
Nominal voltage	[V DC]	24 ±20%
Nominal current	[A]	0.2

Operating conditions		
Ambient temperature	[°C]	0 ... +50
Degree of protection		IP20
Safety function		Safe Torque Off (STO)
Performance Level (PL)		Category 3, Performance Level d
Safety integrity level (SIL)		SIL 2
Certificate issuing authority		BG MFS 09031
CE marking (see declaration of conformity)		To EU EMC Directive To EC Machinery Directive

Technical data – Fieldbus interface				
Interfaces	I/O	CANopen	PROFIBUS DP	DeviceNet
Communication profile	–	DS301, FHPP	DP-V0 / FHPP+	FHPP
	–	DS301, DSP402	–	
Max. fieldbus transmission rate	[Mbps]	1	12	0.5
Interface	Integrated	■	■	–
	Optional	–	–	■ → 573



## Ordering – Product options

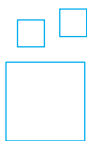

Configurable product

This product and all its options can be ordered using the configurator.

The configurator can be found under Products on the DVD or



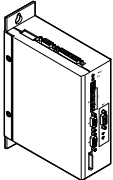

→ [www.festo.com/catalogue/...](http://www.festo.com/catalogue/...)

Enter the type code in the search field.

## Ordering data

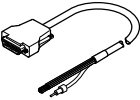
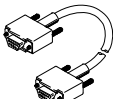
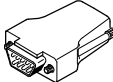
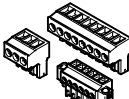
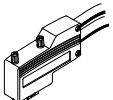
	Description	Part no.	Type
	The plug assortment NEKM (→ 573) is included in the scope of delivery of the motor controller.	572211	CMMS-ST-C8-7-G2

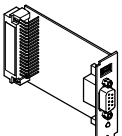
## Accessories – Ordering data

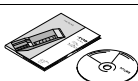
	Part no.	Type		Part no.	Type
<b>Cable and plug</b>					
Control cable, for I/O interface to any controller					
	552254	NEBC-S1G25-K-2.5N-LE26			
Programming cable					
	160786	PS1-ZK11-NULLMODEM-1,5M			
Encoder plug					
	564264	NECC-A-S-S1G9-C2M			
Plug assortment					
	547452	NEKM-C-1			
Plug					
	For PROFIBUS interface				
	533780	FBS-SUB-9-WS-PB-K			
	For CANopen interface				
	533783	FBS-SUB-9-WS-CO-K			
<b>Cable and plug</b>					
Plug, for DeviceNet interface					
	525635	FBSD-KL-2X5POL			
<b>Plug-in card</b>					
	Interface, for PROFIBUS interface				
	★ 547450	CAMC-PB			
	Interface, for DeviceNet interface				
	547451	CAMC-DN			
<b>Memory card for data backup and firmware download</b>					
	1436343	CAMC-M-S-F10-V1			
<b>Documentation and software</b>					
	Ordering data → online: <a href="#">cmms</a>				

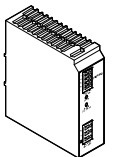
	Nominal output voltage [V DC]	Nominal output current [A]	Part no.	Type
<b>Power supply unit</b>				
	24	5	2247681	CACN-3A-1-5
		10	2247682	CACN-3A-1-10
	48	5	2247683	CACN-3A-7-5
		10	2247684	CACN-3A-7-10
		20	2247685	CACN-11A-7-20
		Technical data online: → <a href="#">cacn</a>		

## Note

If a common power supply unit is used to supply the power section and the control section, the voltage tolerances for the

supply to the control section cannot be maintained at high braking power. This can result in damage to the control sec-

tion.

Always use separate power supply units

to supply the power section and the control section.



Overview/Configuration/Ordering  
→ [www.festo.com/catalogue/emga](http://www.festo.com/catalogue/emga)



Additional information/Support/User documentation  
→ [www.festo.com/sp/emga](http://www.festo.com/sp/emga)

Accessories

Gear units

Gear units for stepper motors

# EMGA-SST



- + Planetary gear unit for stepper motors EMMS-ST
- + Gear ratio  $i = 3$  and  $5$ , available ex-stock
- + Life-time lubrication

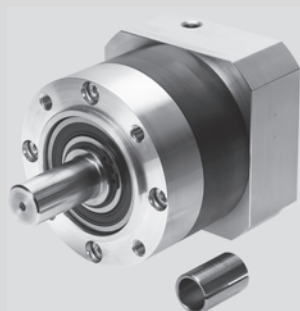

- Low-backlash planetary gear unit
- Gear ratio  $i = 3$  and  $5$ , available ex-stock
- Life-time lubrication
- Protection class IP54
- ★ Quick ordering of basic designs → 576

→ [www.festo.com/catalogue/emga](http://www.festo.com/catalogue/emga)

## Product range overview

Flange size	Output torque [Nm]	Gear ratio	
		3	5
42, 57, 87	17.6 ... 176	■	■

## Data sheet

Technical data		Dimensions → 576					
Motor flange size		42		57		87	
Gear unit type		EMGA-40-P-G...		EMGA-60-P-G...		EMGA-80-P-G...	
Gear ratio	[i]	3	5	3	5	3	5
Continuous output torque <sup>1)</sup>	[Nm]	11	14	22	22	85	110
Max. output torque	[Nm]	17.6	22	35.2	35.2	136	176
Torsional backlash	[deg]	0.25		0.17		0.12	
Moment of inertia <sup>2)</sup>	[kgcm <sup>2</sup> ]	0.031	0.019	0.135	0.078	0.77	0.45
Operating temperature <sup>3)</sup>	[°C]	-25 ... +90					
Degree of protection		IP54					

1) At the output shaft

2) In relation to the drive shaft

3) Note the temperature range of the motor

# Gear units EMGA-SST, for stepper motors

FESTO

## ★ Quick ordering<sup>1)</sup>

Motor flange size	Part no.	Type
42	★ 549428	EMGA-40-P-G3-SST-42
	★ 549429	EMGA-40-P-G5-SST-42
57	★ 549430	EMGA-60-P-G3-SST-57
	★ 549431	EMGA-60-P-G5-SST-57

Motor flange size	Part no.	Type
87	★ 549432	EMGA-80-P-G3-SST-87
	★ 549433	EMGA-80-P-G5-SST-87

1) All products in this table are easy to select and quick to order.

4

## Ordering – Product options

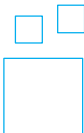

**Configurable product**

**This product and all its options can be ordered using the configurator.**

The configurator can be found under Products on the DVD or  
[→ www.festo.com/catalogue/...](http://www.festo.com/catalogue/...)

Enter the type code in the search field.

## Dimensions

Download CAD data [→ www.festo.com](http://www.festo.com)

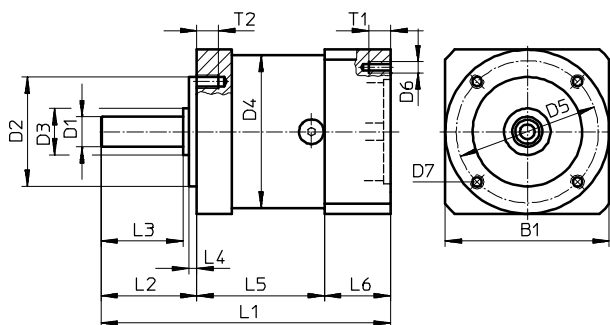

Motor flange size	B1	D1 ∅ h7	D2 ∅ h7	D3 ∅	D4 ∅	D5 ∅	D6	D7
42	40	10	26	12	40	34	∅3.4	M4
57	60	11	40	17	60	52	M4	M5
87	90	20	60	25	80	70	M5	M6

Motor flange size	L1	L2	L3	L4	L5	L6	T1	T2
	±1.5		±0.2	±0.2				
42	92.5	26±0,6	23	2	39	27.5	5	6
57	106	35±0,8	30	3	47	24	8	8
87	135.5	40±0,8	36	3	60	35.5	12	10



Overview/Configuration/Ordering  
→ [www.festo.com/catalogue/emga](http://www.festo.com/catalogue/emga)



Additional information/Support/User documentation  
→ [www.festo.com/sp/emga](http://www.festo.com/sp/emga)

Accessories  
Gear units

Gear units for servo motors

# EMGA-SAS

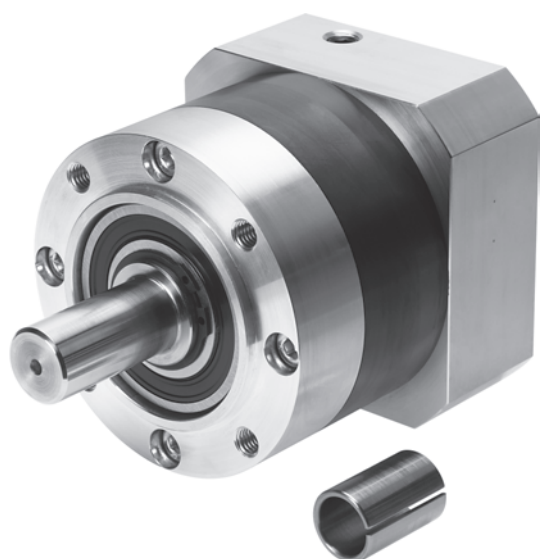

- + Planetary gear unit for servo motors EMMS-AS
- + Gear ratio  $i = 3$  and  $5$ , available ex-stock
- + Life-time lubrication

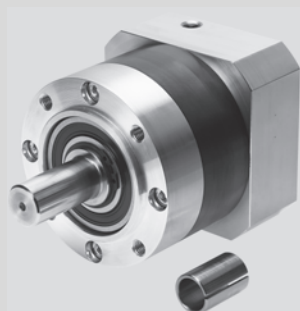

- Low-backlash planetary gear unit
- Gear ratio  $i = 3$  and  $5$ , available ex-stock
- Life-time lubrication
- Protection class IP54

→ [www.festo.com/catalogue/emga](http://www.festo.com/catalogue/emga)

## Product range overview

Flange size	Output torque [Nm]	Gear ratio	
		3	5
40 ... 140	17.6 ... 720	■	■

## Data sheet

Technical data		Dimensions → 579							
Motor flange size		40		55		70			
Gear unit type		EMGA-40-P-G...-40		EMGA-60-P-G...-55		EMGA-60-P-G...-70		EMGA-80-P-G...-70	
Gear ratio	[i]	3	5	3	5	3	5	3	5
Continuous output torque <sup>1)</sup>	[Nm]	11	14	22	22	22	22	85	110
Max. output torque <sup>2)</sup>	[Nm]	17.6	22	35.2	35.2	35.2	35.2	136	176
Torsional backlash	[deg]	0.25		0.17		0.17		0.12	
Moment of inertia <sup>3)</sup>	[kgcm <sup>2</sup> ]	0.031	0.019	0.135	0.078	0.135	0.078	0.77	0.45
Operating temperature <sup>4)</sup>	[°C]	-25 ... +90							
Degree of protection		IP54							

Motor flange size		100				140			
Gear unit type		EMGA-80-P-G...-100		EMGA-120-P-G...-100		EMGA-120-P-G...-140		EMGA-160-P-G...-140	
Gear ratio	[i]	3	5	3	5	3	5	3	5
Continuous output torque <sup>1)</sup>	[Nm]	85	110	115	195	115	195	400	450
Max. output torque <sup>2)</sup>	[Nm]	136	176	184	312	184	312	640	720
Torsional backlash	[deg]	0.12		0.12		0.12		0.1	
Moment of inertia <sup>3)</sup>	[kgcm <sup>2</sup> ]	0.77	0.45	2.63	1.53	2.63	1.53	12.14	6.07
Operating temperature <sup>4)</sup>	[°C]	-25 ... +90							
Degree of protection		IP54							

1) At the output shaft

2) The specifications refer to an output shaft speed of 100 rpm as well as operating mode S1 and a temperature of 30 °C.

3) In relation to the drive shaft

4) Note the temperature range of the motor

## Ordering – Product options

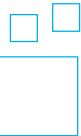

**Configurable product**

**This product and all its options can be ordered using the configurator.**

The configurator can be found under Products on the DVD or  
→ [www.festo.com/catalogue/...](http://www.festo.com/catalogue/...)

Enter the type code in the search field.

## Ordering data

Motor flange size	Part no.	Type
40	552186	EMGA-40-P-G3-SAS-40
	552187	EMGA-40-P-G5-SAS-40
	★ 2297684	EMGA-40-P-G3-EAS-40
	★ 2297685	EMGA-40-P-G5-EAS-40
55	552188	EMGA-60-P-G3-SAS-55
	552189	EMGA-60-P-G5-SAS-55
	★ 2297686	EMGA-60-P-G3-EAS-60
	★ 2297687	EMGA-60-P-G5-EAS-60
70	552190	EMGA-60-P-G3-SAS-70
	552191	EMGA-60-P-G5-SAS-70
	552192	EMGA-80-P-G3-SAS-70
	552193	EMGA-80-P-G5-SAS-70
	★ 2297690	EMGA-80-P-G3-EAS-80
	★ 2297691	EMGA-80-P-G5-EAS-80

Motor flange size	Part no.	Type
100	★ 552194	EMGA-80-P-G3-SAS-100
	★ 552195	EMGA-80-P-G5-SAS-100
	★ 552196	EMGA-120-P-G3-SAS-100
	★ 552197	EMGA-120-P-G5-SAS-100
140	552198	EMGA-120-P-G3-SAS-140
	552199	EMGA-120-P-G5-SAS-140
	552200	EMGA-160-P-G3-SAS-140
	552201	EMGA-160-P-G5-SAS-140

## Dimensions

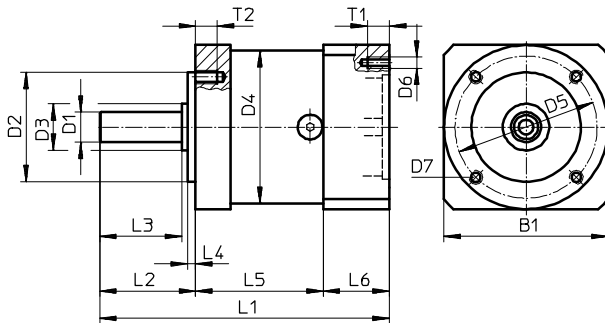
Download CAD data → [www.festo.com](http://www.festo.com)

Type	B1	D1 ∅ h7	D2 ∅ h7	D3 ∅	D4 ∅	D5 ∅	D6	D7
EMGA-40-...-40	40	10	26	12	40	34	M3	M4
EMGA-60-...-55	60	11	40	17	60	52	M5	M5
EMGA-60-...-70	70	11	40	17	60	52	M5	M5
EMGA-80-...-70	80	20	60	25	80	70	M5	M6
EMGA-80-...-100	100	20	60	25	80	70	M8	M6
EMGA-120-...-100	115	25	80	35	115	100	M8	M10
EMGA-120-...-140	140	25	80	35	115	100	M10	M10
EMGA-160-...-140	140	40	130	55	160	145	M10	M12

Type	L1	L2	L3 ±0.2	L4 ±0.2	L5	L6	T1	T2
EMGA-40-...-40	88.5±1,5	26±0,6	23	2	39	23.5	6	6
EMGA-60-...-55	106±1,5	35±0,8	30	3	47	24	12	8
EMGA-60-...-70	106±1,5	35±0,8	30	3	47	24	12	8
EMGA-80-...-70	133.5±1,5	40±0,8	36	3	60	33.5	12	10
EMGA-80-...-100	143.5±1,5	40±0,8	36	3	60	43.5	16	10
EMGA-120-...-100	176.5±2	55±0,8	50	4	74	47.5	20	16
EMGA-120-...-140	186±2	55±0,8	50	4	74	57.5	25	16
EMGA-160-...-140	255.5±2	87±0,8	80	5	104	64.5	25	20

